



Food and Agriculture
Organization of the
United Nations

SUSTAINABLE
DEVELOPMENT
GOALS

working for Zero Hunger

THEMATIC CATALOGUE for SMALLHOLDER FARMERS to PROMOTE INNOVATION

Unlocking the potential of agriculture innovation for family farmers: A thematic catalogue of successful innovations



TECA

TECHNOLOGIES
and PRACTICES
for SMALL
AGRICULTURAL
PRODUCERS

THEMATIC CATALOGUE for SMALLHOLDER FARMERS to PROMOTE INNOVATION

Unlocking the potential of agriculture innovation for family farmers: A thematic catalogue of successful innovations



Required citation:

FAO. 2018. *Unlocking the potential of agriculture innovation for family farmers - Thematic catalogue for smallholder farmers to promote innovation*. 100 pp. Licence: CC BY-NC-SA 3.0 IGO.

The designations employed and the presentation of material in this information product do not imply the expression of any opinion whatsoever on the part of the Food and Agriculture Organization of the United Nations (FAO) concerning the legal or development status of any country, territory, city or area or of its authorities, or concerning the delimitation of its frontiers or boundaries. The mention of specific companies or products of manufacturers, whether or not these have been patented, does not imply that these have been endorsed or recommended by FAO in preference to others of a similar nature that are not mentioned.

The views expressed in this information product are those of the author(s) and do not necessarily reflect the views or policies of FAO.

ISBN 978-92-5-131092-2

© FAO, 2018



Some rights reserved. This work is made available under the Creative Commons Attribution-NonCommercial-ShareAlike 3.0 IGO licence (CC BY-NC-SA 3.0 IGO; <https://creativecommons.org/licenses/by-nc-sa/3.0/igo/legalcode/legalcode>).

Under the terms of this licence, this work may be copied, redistributed and adapted for non-commercial purposes, provided that the work is appropriately cited. In any use of this work, there should be no suggestion that FAO endorses any specific organization, products or services. The use of the FAO logo is not permitted. If the work is adapted, then it must be licensed under the same or equivalent Creative Commons licence. If a translation of this work is created, it must include the following disclaimer along with the required citation: "This translation was not created by the Food and Agriculture Organization of the United Nations (FAO). FAO is not responsible for the content or accuracy of this translation. The original English edition shall be the authoritative edition.

Disputes arising under the licence that cannot be settled amicably will be resolved by mediation and arbitration as described in Article 8 of the licence except as otherwise provided herein. The applicable mediation rules will be the mediation rules of the World Intellectual Property Organization <http://www.wipo.int/amc/en/mediation/rules> and any arbitration will be conducted in accordance with the Arbitration Rules of the United Nations Commission on International Trade Law (UNCITRAL).

All photos, images and drawings are courtesy of the technology providers unless otherwise explicit on the photo.

Third-party materials. Users wishing to reuse material from this work that is attributed to a third party, such as tables, figures or images, are responsible for determining whether permission is needed for that reuse and for obtaining permission from the copyright holder. The risk of claims resulting from infringement of any third-party-owned component in the work rests solely with the user.

Sales, rights and licensing. FAO information products are available on the FAO website (www.fao.org/publications) and can be purchased through publications-sales@fao.org. Requests for commercial use should be submitted via: www.fao.org/contact-us/licence-request. Queries regarding rights and licensing should be submitted to: copyright@fao.org.

Contents

1	Agricultural Mechanization The FAO-Thiaroye Processing Technique Hot to construct and assemble its components	1
2	Beekeeping How to Construct a Smoker for Beekeeping	7
3	Capacity Development Dried Meat Techniques: Examples from Different Regions	17
4	Climate Change Adaptation and Disaster Risk Reduction Rainwater Harvesting Systems for Cabbage Growing in Uganda	23
5	Crop Production Indoor Oyster Mushroom Cultivation for Livelihood Diversification and Increased Resilience in Uganda	29
6	Fishery and Aquaculture Deep Water Culture Aquaponic Unit: Step by Step Description	37
7	Forestry Evergreen Agriculture: Conservation Agriculture in Maize Production in Malawi	51
8	Livestock Production Animal Husbandry in Organic Agriculture	61
9	Natural Resources Management Risk Reduction while Using Pesticides	73
10	Nutrition for Better Life How to Harvest Honey, Pollen and Propolis from Stingless Bees	81
11	Post-harvest and Marketing Increasing Yield of Mango Plantations	87

Contributors

The innovations, technologies and practices contained in this catalogue have been developed in collaboration with the German Corporation for International Cooperation (GIZ), International Federation of Organic Agriculture Movements (IFOAM), Swisscontact, the University of the Philippines, Los Baños, and the World Agroforestry Centre (ICRAF), with the support of the Food and Agriculture Organization of the United Nations' Departments of Agriculture and Consumer Protection as well as the Department of Fisheries and Aquaculture.

Organizations interested in developing and sharing their technologies and practices on TECA can contact the TECA team.

**This catalogue
presents a
set of **eleven
technologies and
practices** across
eleven categories
helping smallholder
farmers and
organisations
to access
innovations.**



Agricultural Mechanization

Agricultural mechanization describes the application of tools, implements and powered machinery as inputs to achieve agricultural production.

Agricultural mechanization enhances the workflow and sets standards for the processing, allowing easier access to agricultural markets.

Under this category, you will find technologies and practices on mechanized tools, which apply to crop production, harvesting and preparation for storage, on-farm processing and rural transport.

The agricultural mechanization category covers the Sustainable Development Goals of no poverty, zero hunger, good health and well-being as well as responsible consumption and production.

On the FAO-TECA platform, there are currently 66 technologies and practices within this category: 43 in English, 13 in Spanish, 5 in French and 5 in Portuguese.



1 **FAO-Thiaroye** **processing technique** **How to construct it and** **assemble its components**

Summary

The FTT-Thiaroye is a technique drawn from the collaborative efforts between the FAO and the National Training Center for Fisheries and Aquaculture Technicians (CNFTPA) training institute in Senegal. Its development addresses the need to improve small-scale fish drying and smoking operations. The key to its adoption rests upon its benefits. Globally, the main condition required for the FAO-Thiaroye technique to be successfully applied is the know-how of its construction, use and maintenance.

Description

1. Overview of the comparative advantages of the FTT-Thiaroye

The FTT-Thiaroye is an innovative and polyvalent technique with important advantages for each actor of the fisheries supply chain. First, the FTT allows dried and smoked products that better meet food safety requirements. This results in a positive endorsement by the competent authority in charge of certifying products placed on the market, be it at the national, regional or international levels. Consumer confidence is also enhanced with superior quality products that better meet their expectations. Second, the FTT allows drying and smoking operations regardless of weather conditions. Consequently, post-harvest losses, which may exceed 50 percent during the rainy

season or cloudy days are better controlled. But the FTT-Thiaroye also provides opportunities for additional revenue for fish operators, with the possibility to process by-products. Fat gathered through the fat collection tray allows, for example, the manufacturing of soap, or can be used as cooking or frying oil.

Finally, we can say that the FTT-Thiaroye practice reduces the wood or coal to fish ratio, and it is also adaptable to other fuels such as coconut husks and shells, stems or corncobs, sugar cane bagasse, etc. Overall, the use of the FTT presupposes less deforestation, better protection of mangroves, thus resulting in positive conservation of natural resources. Talking specifically about gender concerns, the use of the FTT-Thiaroye practice reduces female fish processors drudgery, including a lower exposure to smoke and heat. At the same time, women spend less time on fish processing, allowing them to engage in household chores simultaneously.

Up to now, prototypes of the FAO-Thiaroye technique have been provided through technical cooperation programmes implemented by FAO in some African countries. Many of them are used within post-harvest fish technology platforms constructed to address challenges and key issues in small-scale fisheries; others were offered to institutions whose first calling is to export smoked fish to European Union countries.

The FAO-Thiaroye is a technology built on the strengths of existing improved ovens (kiln) that are adopted all over Africa, such as the Chorkor, Banda, or Altona while correcting their shortcomings to come up with accessories available locally and suitable for small-scale processing operations.



Figure 1: Ember Furnace

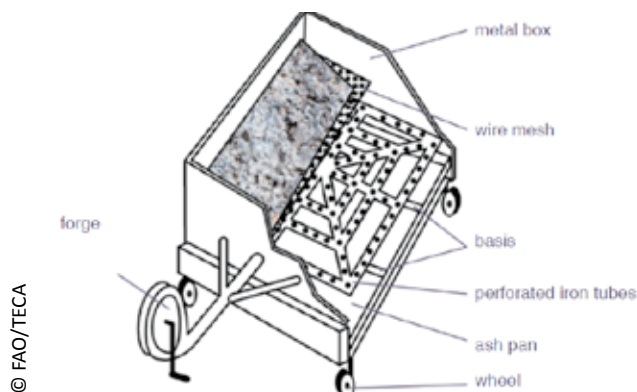

These kilns become FTT when some specific components are added to them, and these are: (1) the ember furnace, (2) the fat-collection tray, (3) the indirect smoke generator system, and (4) the hot-air distributor.

1.1 The ember furnace

The ember furnace is meant to hold the fuel used to cook the fish. Loading it in the fireplace concentrates the heat on the product.

The furnace should fit the dimensions of the kiln's gate, and it mainly consists of a metal box that is 26 cm high and 1 m wide. As such, the furnace is 98 cm long, and 88 cm wide, with a mesh of 5 mm netting, 97 cm long, and 87 cm wide.

The materials used for the construction of the furnace are:

- one galvanized steel sheet with a thickness of 1.5 mm;
- one piece of cornière (length: 5.80 m; width: 30 mm);
- one piece of flat iron (25 mm);
- one piece of forge;
- four pieces of metal wheels; and
- two pieces of the handle.

The furnace can be improved by equipping it with a detachable pull-tab that fits on with a pipe placed on the front of the furnace.

Figure 2: Fat-collection tray





Figure 3: Smoke generator system



1.2 The flat-collection tray

The fat-collection tray is used for collecting fat while cooking the fish. It includes a set of holes allowing the heat from the stove to reach the fish on the rack, and each hole is topped with a cone-shaped cap allowing the fat and exudate to drip on the tray that will be slightly tilted so that the oil can drip towards the edge.

The oil will be collected in a container placed outside the furnace through the pipes welded at the end edges of the tray. The size of the fat-collection tray may vary but must fit the kiln in which it will be placed.

To manufacture the fat-collection tray, the following are usually need:

- one galvanized steel sheet of 2 m long, 1 m wide and 1.5 mm thick;
- two bars of 30 mm flat iron; and
- one bar of 6 mm iron rod.

A more convenient model would have an opening made in the kiln. It is fitted out with parallel runners allowing the fat-collection tray to slide and be removed more easily without touching the rack as it is now equipped with two handles.

1.3 The indirect smoke generator system

The indirect smoke generator system consists of a metal barrel welded to a metal tube that is about 1.5 m long and 30 cm in diameter. The metal tube can be shaped into a spiral or circular tube depending on the available space. It also includes a

Figure 4: Hot-air distributor

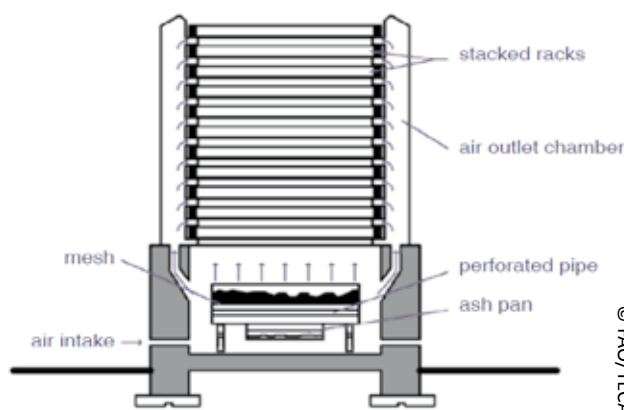



metal casing in which the filter is inserted. All of these are then inserted into a metal housing.

1.4 The hot-air distributor

The hot-air distributor (Figure 4) is composed of two metal boxes. Inside each of these, horizontal fins match the number of drying racks and perfectly fit them. The drying racks are stacked and arranged vertically. A metal pipe connects the furnace to the air distribution box to facilitate the air flow.

The hot air can thus circulate on the racks using the furnace's forge. The hot-air distributor or "air blower" has the same height as all the racks stacked together and the same width as the wall of the compartments (between 30 and 40 cm). It is made up internally of fins like those of aero-evaporators, enabling the hot air to circulate over each rack. As for the aerated rack's frame, its height is increased from 7 cm to 10 cm, and a longitudinal opening is made at a level of 3 cm to allow the warm air through during drying.

As for the fuel sources, wood is generally used, especially for smoking fish products. Agricultural biomass such as bagasse (plant material derived from sugar cane), corn

cobs, millet or rice stalks and coconut husks or shells can also be used as fuel. However, the use of fuels other than wood and plant material for smoking food is to be prohibited.

Fuels such as diesel, rubber (including tires) or waste oil should never be used even as a partial component, as they can significantly increase the level of polycyclic aromatic hydrocarbons (PAHs).

The FTT has been tested and validated firstly in Senegal. Then fish processors in other African countries have also experienced the Thiaroye system, like in Togo, Cote d'Ivoire, Tanzania, and recently in Ghana. The primary user groups of the FTT-Thiaroye are obviously fish processors, the majority of which, in Africa, are women. A training video and a methodological guide (English and French) have been released in that respect.

Further reading

Ndiaye, O., Sodoke Komivi, B. and Diei-Ouadi, Y. 2014. Guide for developing and using the FAO-Thiaroye processing technique (FTT-Thiaroye). Rome, FAO. 67 pp. Available at: <http://www.fao.org/3/a-i4174e.pdf>

Source: FAO



Beekeeping



Beekeeping or apiculture refers to the management of bee colonies, generally in man-made hives.

Under this category, you will find technologies and practices that can support beekeepers around the world to maximize, in a sustainable way, the benefits from beekeeping, whether it concerns beekeeping using traditional, intermediate or modern techniques. They cover the full production process: construction of beekeeping equipment, hive management, bee health, harvesting, processing and marketing of beehive products (honey, propolis, pollen, wax, etc.).

The technologies and practices in this category mainly cover beekeeping with European honey bee (*Apis mellifera*), but you can also find technologies and practices related to beekeeping with stingless bees (meliponiculture) and giant honey bees (*Apis dorsata*).

The beekeeping category covers the Sustainable Development Goals of no poverty, zero hunger, good health and well-being, decent work and economic growth, as well as responsible consumption and production.

On the FAO-TECA platform, there are currently 111 technologies and practices within this category: 41 in English, 40 in Spanish and 30 in French.



2 How to construct a smoker for beekeeping

Summary

The smoker is an essential tool for any beekeeper. Since long time ago, smoke has been used to calm down the bees when handling beehives. This technology describes the materials, tools and procedures needed to manufacture a smoker.

Description

The smoker is a sturdy container resistant to high temperatures. Inside the smoker, organic matter will be burnt to produce smoke. Care should be taken to make sure, only abundant white cold smoke comes out of the smoker and not to burn the bees. The smoke is used to calm down the bees and to make operations in the hive easier. For the bees, smoke is the alarm for fire: they think there is a forest fire and in preparation for leaving the hive, they begin to suck the nectar they have stored in the cells and lose their instinct to sting. This is a natural behaviour of the bees.

The most used smoker model consists of a bellows (blower) attached to a cylindrical metal body, which can carry a protective grid if desired, and that is connected through a hinge to a conical lid with a hole through which the smoke leaves the smoker (Figure 1). Inside the cylinder, there is a grid on which the fuel is placed. Through a hole in the cylindrical body, located below the base of the grid, the air produced by the blower is introduced into the combustion chamber. The most commonly used fuels are dry leaf litter, wood sawdust, dry grass, corncobs or another organic substrate harmless to bees.

Figure 1: Smoker for the beekeeper



© FAO/TECA

1. Material needed for the construction of the smoker

Nowadays it is possible to find smokers of different sizes, shapes and materials. All of them use the bellows principle. The most commonly used materials for the smoker body and lid are galvanized zinc sheet (26 mm gauge) and stainless steel. Other materials needed are wood, a piece of leather, nails, screws, a hinge and a spring. In addition, tools such as a cutter, knife or scissors, hammer and protective gloves are necessary.

Figure 2: Components of a smoker

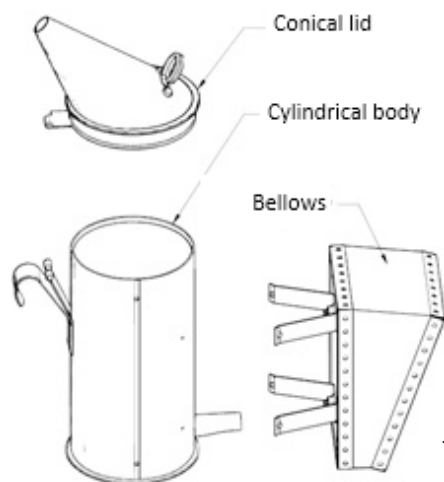

© FAO/TECA



2. Parts of a smoker

- **Combustion chamber:** it is the largest part of the smoker, where combustion is carried out to produce the smoke.
- **Grid:** protects the bottom of the combustion chamber. It also prevents the passage of the flame through the air conductor tube (8) of the smoker and facilitates the uniform distribution of air from the bellows (blower).

Figure 3: Parts of a smoker

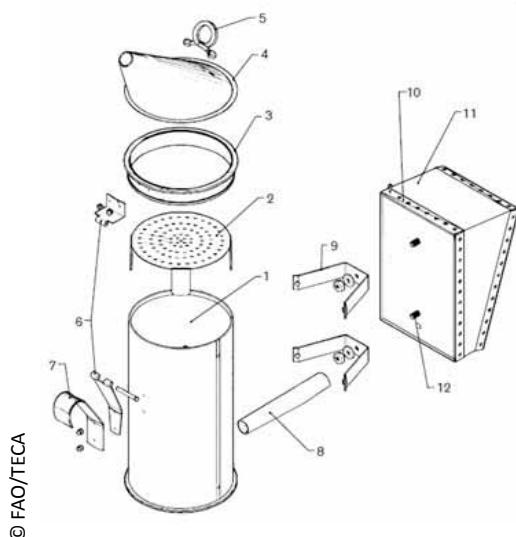

- **Coupling ring:** it is the piece that allows the coupling of the combustion chamber with the conical lid (4).
- **Conical lid:** the lid allows the accumulation of the smoke flow through an outlet at the top.
- **Handle:** facilitates opening the smoker especially when it is hot.
- **Hinge:** allows to open the smoker and close it easily.
- **Hook:** this piece allows to hang the smoker on the hive so that the beekeeper can have two hands-free to manipulate the hive.

- **Air conducting tube:** allows a better flow of air from the bellows to the combustion chamber (optional).
- **Bellows support:** these two metal parts keep the bellows and combustion chamber strongly together.
- **Galvanized strip:** used to seal the wooden plate of the bellows and the leather together, in order to prevent the leak of air.
- **Vinyl or leather:** flexible material of high strength used to exert air propulsion inside the smoker.
- **Bellows holding screw:** two screws that hold the bellows to the bellows support.

3. Description of the parts of a smoker

3.1 Conical Lid

The conical lid is made of a piece of metal with the dimensions and angles as indicated in figure 10.4. It can be welded or moulded with heat to achieve its complete bending and assembly. Three holes should be made in the part close to the base of the lid to attach the handle.

3.2 Coupling ring

This piece allows the precise and adjusted coupling of the conical lid and the combustion chamber. It is made with a metal strip of 3.8 cm wide and 42.6 cm long. A short ring with a diameter of 12.8 cm should be made by connecting the two ends of the metal strip. The ends should be overlapped by 0.9 cm. To assemble the coupling ring and the conical lid without using more materials and to facilitate their union, three inflexions or bends must be made in the metal strip using pliers (see Figure 5). The coupling ring should be adjusted until it is fixed to the conical lid (see Figure 6).



Figure 4: Measurements of the conical lid

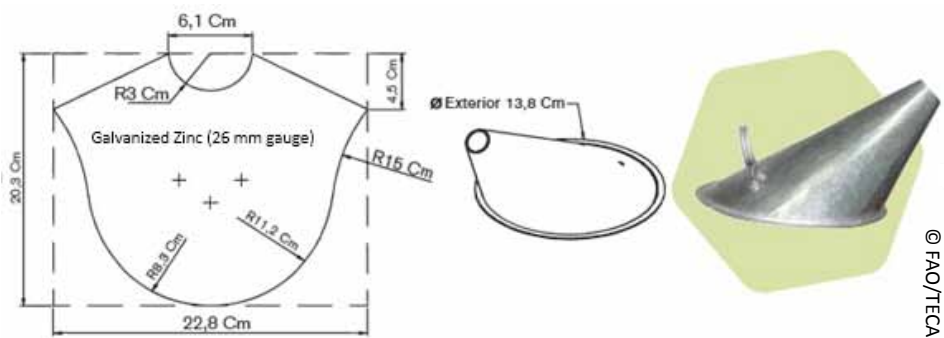

Figure 5: Coupling ring measurements

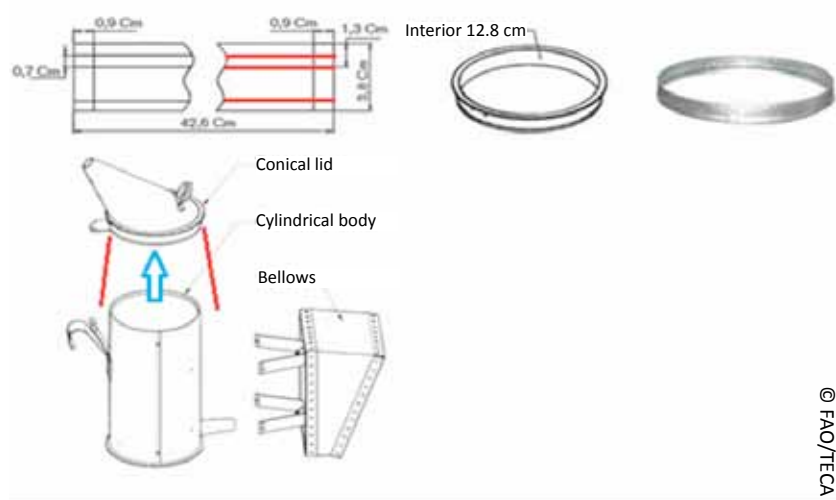
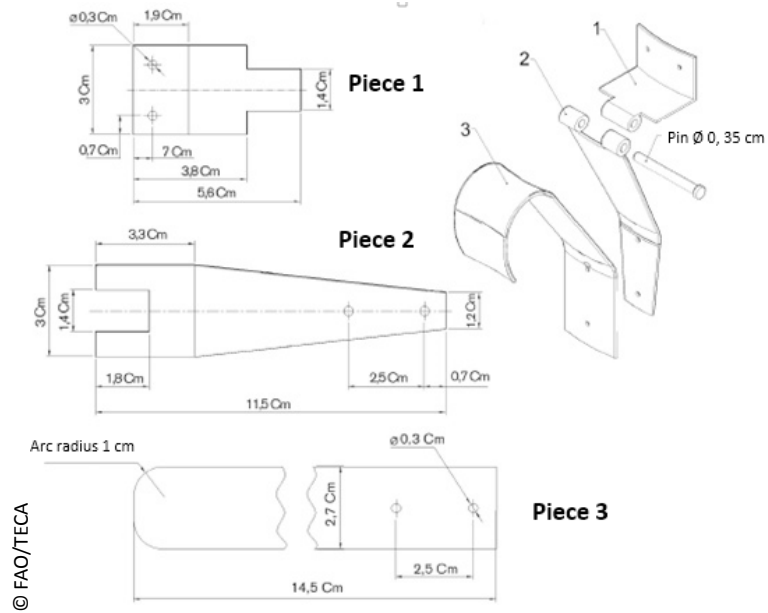

Figure 6: Coupling ring and a conical lid fixed



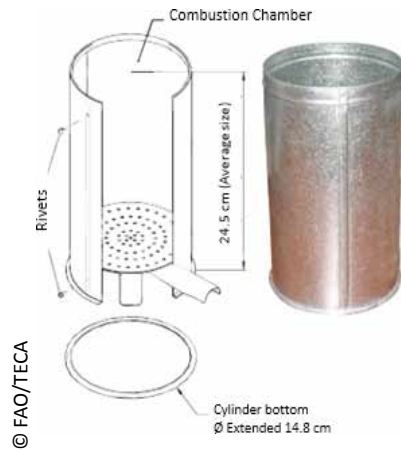

Figure 7: Hinge and hook for support



© FAO/TECA

Figure 8: Parts and measurements of the cylinder



© FAO/TECA

Figure 9: Measurements of the cylinder or combustion chamber

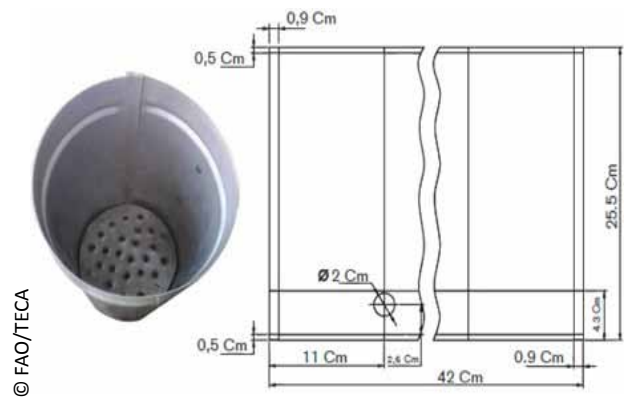

© FAO/TECA



3.3 Hinge and hook for support

To hang the smoker a hinge and hook have to be incorporated. Three metal parts and a metal pin are required.

3.3.1 Piece one

It is the upper support of the hinge, which joins the conical cover with the lower part of the hinge. This piece must have two holes to fix it to the conical cover, and the end must be rolled to fit the size of the pin.

3.3.2 Piece two

This is attached to the combustion chamber. It has two extensions of 1.8 cm x 0.8 cm that are rolled to be coupled with Piece one through the pin.

3.3.3 Piece three

This is the hook to hang the smoker being a long metal piece with a rounded unsharpened edge. It has two holes to fix it to the conical cover.

3.4 The cylinder (combustion chamber)

The combustion chamber is composed of the base, the grid, the cylinder and the air conducting tube. The base is a circular metal piece with a diameter of 14.8 cm that is joined and fixed to the combustion chamber. The grid can be fixed or removable, and there has to be a space between the grid and the bottom of the cylinder to allow the access of air. The cylinder must be closed by overlapping of its two ends and fixing them using rivets to avoid the escape flames or smoker. The cylinder has a size of 42 cm x 24.5 cm and must be closed using two rivets. The inner diameter of the cylinder is 14.8 cm (diameter of the fuel grid) and must have inflexion in the upper part. This is where the coupling ring will be attached to the conical cylinder.

3.5 Air conducting tube connected to the combustion chamber

The air conducting tube guides the air from the bellows to the combustion chamber. It can be fixed to the combustion chamber with rivets or it can be welded.

3.6 Fuel grid

The fuel grid must have as many holes as possible with a diameter of 0.3 cm to allow the passage of air to the combustion. The grid can be removable (allows to clean the smoker better) or fixed (less handling is possible, and deterioration of the material is faster).

3.7 Parts and measurements of the bellows

Once all the pieces below have been assembled, it is recommended to check the smoker operation before using it to work in the hive.

3.7.1 Bellows

Bellows are constructed with:

- two wooden bases of rectangular shape (12.7 cm x 19 cm x 1.3 cm);
- a conical spring of 9 cm of base (diameter) and 13 cm of height. (the spring can be the type used in furniture);
- two strips of galvanic sheets to join and seal the bellows; and
- a piece of leather that provides mobility to the bellows.

3.7.2 Bellows support

Two plates with the indicated measures are required for fixing the bellows and the combustion cylinder.

3.7.3 Piece of vinyl or leather

The leather (or vinyl) must be one piece. If extensions are needed, they must be done in the lower part of the bellows, and they must be reinforced to avoid air leaks.



Figure 10: Air conducting tube connected to the combustion chamber

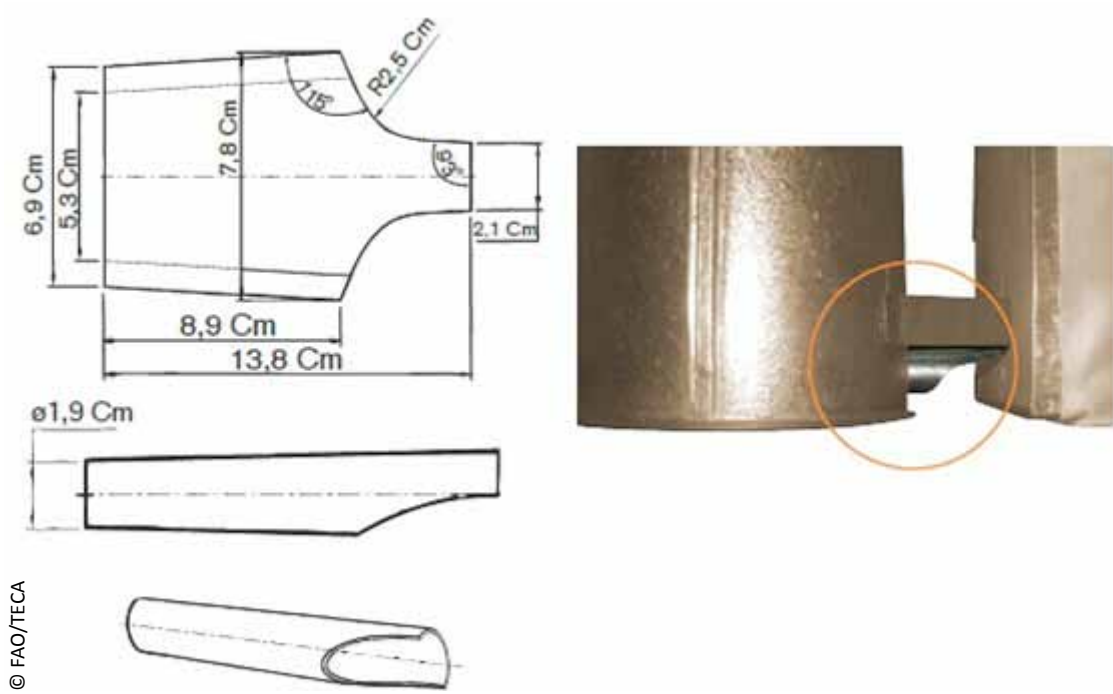
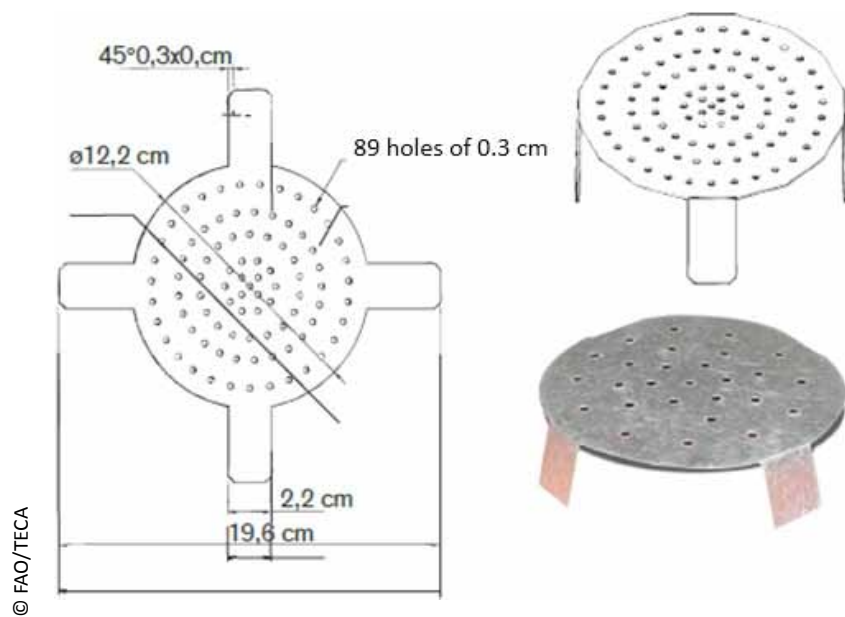

Figure 11: Fuel grid





It is important that the piece is complete and without perforations.

Once all the pieces have been assembled, it is recommended to check the smoker operation before using it to work in the hive.

4. Recommendations for using the smoker

The smoker is used to calm down the bees and reduce stinging behaviour of the bees, making the work in the hive easier.

It is important that the smoker is cleaned after each use and that the remaining of burning materials are properly extinguished after each use to avoid causing unintentional burning and to keep the smoker in good condition for as long as possible.

It is important that the smoker contains a sufficient amount of burning material, so it does not have to be opened and filled again in the middle of a hive inspection.

In addition, the material that burns must be organic matter and not oily materials. Although it seems easier to light these products, they can alter the bees and contaminate the honey.

A good way to light the smoker is using a piece of paper in the bottom of the smoker, and once it is burning, the organic matter should be slowly introduced as the amount of smoke increases. Many people add green leaves of aromatic plants such as Thyme (*Thymus vulgaris*) or Rosemary (*Rosmarinus officinalis*) to moisten, aromatize the smoke, and to decrease in the varroa load.

Another important point is that the amount of smoke used at the time of handling the hives should be as minimal as possible, so the bees do not choke. Also, using too much smoke can alter the taste of the honey. It is also important that the smoker always contains a sufficient amount of organic

Figure 12: Parts and measurements of the bellows

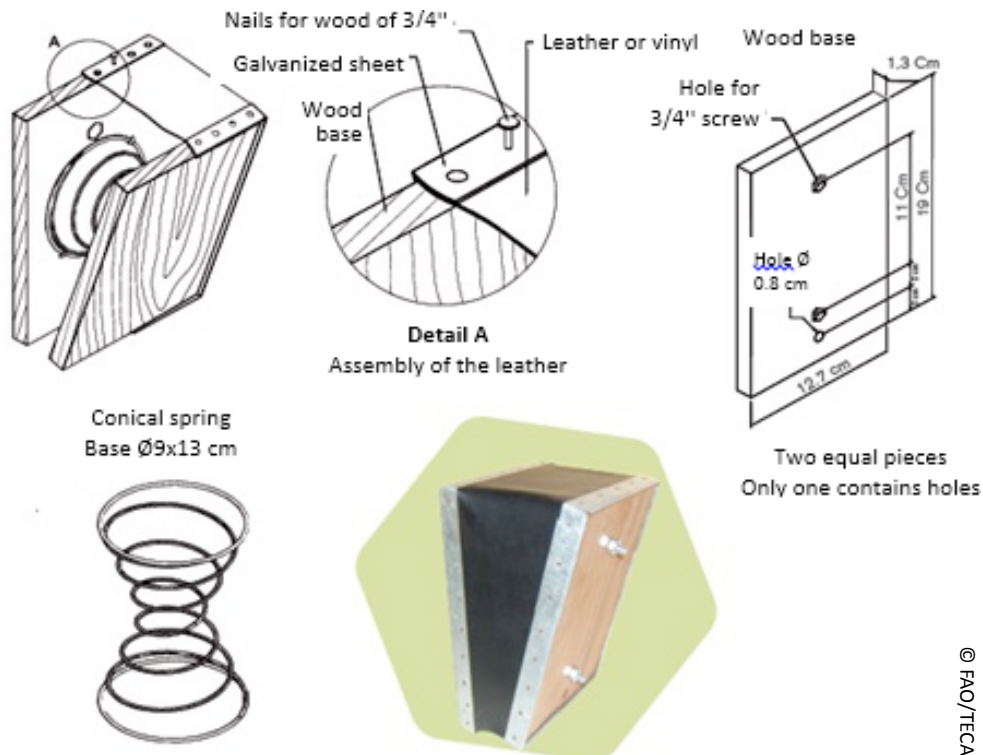

© FAO/TECA



Figure 13: Measurements of the bellows support

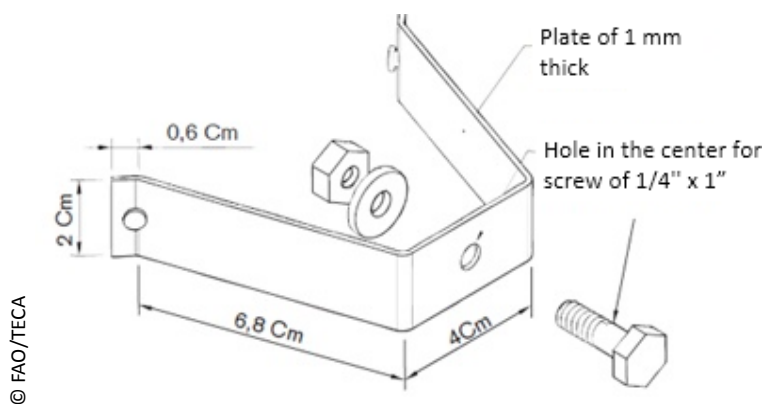
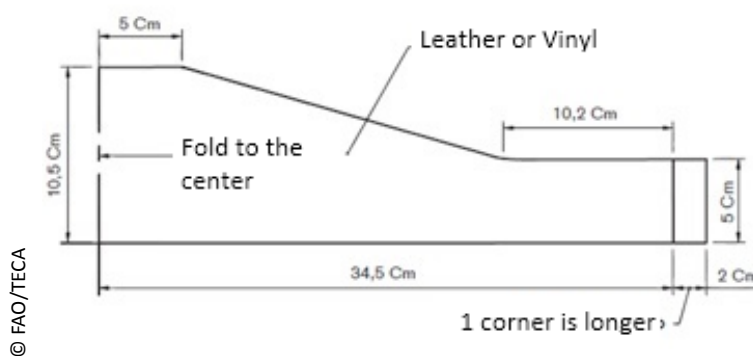

Figure 14: Leather measurements



matter for burning and that no hot particles and/or ashes come out, as these can irritate and burn the bees.

Figure 15: Beekeepers using the smoker



5. Validation

This technology was developed within the Pymerural Project, a collaboration between the government of Nicaragua and Honduras. The Swiss cooperation also sponsored the programme and offered technical support through the Swisscontact foundation.

This document is a translation of the original “Confección de ahumador para apicultor” (FAO-TECA technology number 8295)

Source: Swisscontact



Capacity Development



Capacity development is “the process through which individuals, organizations and societies obtain, strengthen and maintain the capabilities to set and achieve their own development objectives over time” (UNDP).

Technologies and practices under this category include community-based approaches for production, processing and marketing of agricultural products, and participatory varietal selection among others.

The capacity development category covers the Sustainable Development Goals of no poverty, zero hunger, good health and well-being as well as responsible consumption and production.

On the FAO-TECA platform, there are currently 249 technologies and practices within this category: 169 in English, 40 in Spanish, 25 in French and 15 in Portuguese.



3 Dried meat techniques: Examples from different regions

Summary

Drying meat under natural temperatures, humidity and circulation of the air, including the direct influence of sun rays, is the oldest method of meat preservation. However, various methods, typical for different regions, exist to produce dried meat with or without additional treatment. The following examples of dried meat techniques are part of FAO's publication: Manual on simple methods of meat preservation, which is mainly intended to disseminate information on traditional methods of meat preservation and addresses aspects of hygienic slaughtering under rural conditions in Africa.

Description

1. Techniques in different parts of the world

There are different techniques for drying meat in various parts of the world.

1.1 Odka (Somalia and other East African countries)

Odka is basically a sun-dried meat product made of lean beef and is of major importance to nomads in Somalia. In the face of perennial incidence of drought in the Horn of Africa, odka has become important since it is often prepared from drought-stricken livestock. However, the meat strips cut for drying are bigger, and dry salting is usually applied instead of brine salting. After only four to six hours' sun-drying the large pieces of meat are cut into smaller strips and cooked in oil. After

this heat treatment, drying is continued, and finally, sauces and spices are added. For storage, odka is again covered with oil and, when kept in a tightly closed container, it has a shelf-life of more than 12 months.

1.2 Qwanta (Ethiopia and other East African countries)

Qwanta is manufactured from lean muscles of beef which are further sliced into long strips ranging from 20 to 40 cm and are hung over the wire in the kitchen to dry for 24 to 36 hours. Prior to drying, the strips are coated with a sauce containing a mixture of salt (25 percent), hot pepper or chilli (50 percent) and aromatic seasoning substances (25 percent). After air drying, the meat pieces may be further exposed to light wood smoke and are then fried in butterfat and dried again to some extent. At this stage, the product is ready for consumption or storage.

1.3 Kilishi (Nigeria and other arid or semi-arid zones of West Africa)

Kilishi is a product obtained from sliced lean muscles of beef, goat meat or lamb and is made on a large scale under the hot and dry weather conditions prevailing from February to May. It is produced by the sun-drying thin slices of meat. However, recent experience indicates that kilishi can also be produced industrially using tray-drying in a warm air oven. Connective tissue and adhering fatty material are trimmed off the meat which is cut with a curved knife into thin slices of about 0.5 cm thickness, 15 cm length and as much as 6 cm width.

Traditionally, the slices of meat are spread on papyrus mats on elevated platforms or tables in the sun for drying. However, these papyrus mats may lead to hygienic problems, especially after repeated use.



Therefore, easily washable corrosion-free wire nets or plastic nets are recommended for horizontal drying. The vertical drying method is also recommended in this case. Sun-drying of kilishi could also be improved by the use of solar dryers. These devices will increase the rate of drying of the product and keep insects and dust from the product.

In the first stage of drying, which takes two to six hours, the moisture of the meat slices has to be reduced to about 40 to 50 percent. The slices are then put into an infusion containing defatted wet groundnut cake paste or soybean flour as the main component (about 50 percent), and is further composed of water (30 percent), garlic (10 percent), bouillon cubes (5 percent), salt (2 percent) and spices such as pepper, ginger and onion. The dried slices of meat should absorb the infusion up to almost three times their weight.

After infusion, the wet product is again exposed to the sun to dry. Drying at this stage is much faster than at the first stage. When the moisture content of the slices has been reduced to 20 to 30 percent, a process which takes two to three hours depending on weather conditions and the dimensions of the product, the slices are finally roasted over a glowing fire for about five minutes. The roasting process helps to enhance desirable flavour development and to inactivate contaminating micro-organisms. Roasted kilishi is therefore superior in flavour to the unroasted version. After roasting, the final moisture content ranges between 10 to 12 percent. It will decrease during storage at room temperature to as low a level of 7 percent. When packaged in hermetically sealed, low-density plastic bags the product remains remarkably stable

at room temperature for a period of about one year.

Figure 1: Whole strips and flat pieces of dried meat and dried meat comminuted to fragments of different sizes for preparing meals

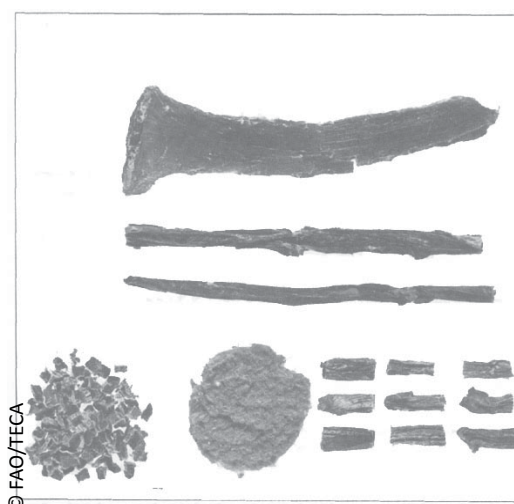

1.4 Biltong (Southern African countries)

Biltong is a well-known salted, dried meat prepared from beef or antelope meat. Most muscles in the carcass may be used, but the largest is the most suitable. The finest biltong with the best flavour is made from the sirloin strip, and the most tender is derived from the fillet.

The meat is cut into long strips (1 to 2 cm thick) and placed in brine, or dry-salted, which is actually the most popular method. Common salt, preferably coarse salt (1 to 2 kg for 50 kg of meat), or salt and pepper are the principal ingredients used, although other ingredients such as sugar, coriander, aniseed, garlic or other spices are included in some mixtures to improve flavour. In most cases, nitrate or nitrite is added to achieve a red colour and the typical flavour of cured meat. The addition of 0.1 percent potassium sorbate to the raw meat is permitted in South Africa as a preservative. The salt/spice mixture is rubbed into the meat by hand, and the salted strips are



then transferred to a suitable container. It is recommended that a little vinegar is sprinkled on each firmly packed layer in the container.

Biltong is left in the curing brine for several hours, but not longer than 12 hours (otherwise it will be too salty), and then dipped into a mixture of hot water and vinegar (approx. 10:1). The biltong is now ready for sun-drying for one day. Then the strips are moved into the shade for the rest of the drying period. The product is usually not smoked, but if it is smoked only light cold smoking is recommended, which takes one to two weeks under sufficient air circulation. The biltong is ready when the inside is soft, moist and red in colour, with a hard brown outer layer.

Biltong is sold in sticks or slices. The usual shelf-life is several months without refrigeration and packaging, but in airtight packages, the product stores well for more than one year. Biltong is not heated during processing or before consumption. It is eaten raw and considered a delicacy.

1.5 Pastirma (Turkey, Egypt, Armenia)

Pastirma is salted and dried beef from not too young animals. In some areas, camel meat is also used. The meat is taken from the hindquarters and is cut into 50 to 60 cm long strips with a diameter of not more than 5 cm. The strips are rubbed and covered with salt and nitrate. The dosage of the nitrate in relation to the meat is 0.02 percent, that means 2 g of nitrate for 10 kg of meat. Several incisions are made in the meat to facilitate salt penetration.

The salted meat strips are arranged in piles about 1 m high and kept for one day at room temperature. They are turned over, salted again, and stored in piles for

another day. Thereafter the meat strips are washed and air-dried for two to three days in summer and for 15 to 20 days in winter. After drying, the strips are piled up again to a height of 30 cm and pressed with heavy weights (approx. 1 tonne) for 12 hours. After another drying period of two to three days, the meat pieces are again pressed for 12 hours. Finally, the meat is again air-dried for 5 to 10 days.

After the salting and drying process, the entire surface of the meat is covered with a layer (3 to 5 mm thick) of a paste called cemen, which consists of 35 percent freshly ground garlic, 20 percent helba, 6 percent hot red paprika, 2 percent mustard, and 37 percent water. Helba is used as a binder of the paste; the other ingredients are spices, but garlic is the most important as it is antimycotic. The meat strips covered with cemen are stored in piles for one day, and thereafter are dried for 5 to 12 days in a room with good air ventilation, after which the pastirma is ready for sale. Thus, the production of pastirma requires several weeks. However, not much energy is required since most of the salting and drying is done at room temperature. The final product has an average water activity of 0.88. The salt content should range between 4.5 and 6.0 percent. The product is mould-free for months at ambient temperature even in summer. Pastirma thus has better microbiological stability than biltong.

1.6 Charque (Brazil and other South American countries)

Charque consists of flat pieces of beef preserved by salting and drying. The fresh, raw meat from the fore- and hindquarters is cut into large pieces of about 5 kg, which should not be more than 5 cm thick. The



pieces are submerged in a saturated salt solution for about one hour in barrels or cement vats. On removal from the brine, the meat is laid on slats or racks above the brine tank to drain.

For dry-salting, the flat meat pieces are piled on a sloping, grooved, concrete floor under a roof. To form a pile, salt is spread evenly over the floor about 1 cm high. Then a layer of meat is put on the salt. The meat is covered with another (1 cm) layer of salt followed by adding another layer of meat, and so on until the alternate layers of salt and meat reach a height of about 1 m. The pile is then covered with a few wooden planks and pressed with heavy stones. After eight hours the pile is restacked so that the top meat goes to the bottom of the pile. The restacking process with fresh layers of salt is repeated every day for five days.

The salted meat is then ready for drying. Before initiating drying, the meat pieces are subjected to rapid washing to remove excess salt adhering to the surface. The meat pieces may also be passed through a pair of wooden rollers or a special press to squeeze out some surplus moisture and flatten the meat slabs. The meat is then spread out on bamboo slats or loosely woven fibre mats in a shed or, in industrial production, exposed to the sun on wooden rails which are oriented north-south, thus permitting an even solar coverage.

Initial drying, directly in the sun, is limited to a maximum period of four to six hours. This period of exposure may be subsequently lengthened to a maximum of eight hours. Temperatures in excess of 40°C on the meat surface should be avoided. To ensure even drying over the extended muscle pieces, the meat is placed on the rails during the morning and removed

again in the afternoon. The meat pieces are exposed to the sun each day over a period of four to five days. After each period of exposure, the pieces are collected, stacked in piles on concrete slabs and covered with an impermeable cloth to protect them against rain and wind and to hold the heat absorbed.

When sufficiently dry, the meat pieces are either sold without prior packaging or wrapped in jute sacks. Plastic sacks are not suitable, because the product still contains a certain proportion of its original moisture content, and this moisture must be allowed to drain freely from the product. Charque keeps for months under ambient room conditions and is resistant to infestation by insects and growth of moulds.

Further reading

FAO. 1990. *Manual on simple methods of meat preservation*. Rome
FAO catalogue TECA

Source: FAO

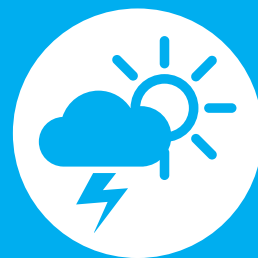

Climate Change Adaptation and Disaster Risk Reduction



The category climate change adaptation and disaster risk reduction is concerned with seeking to lower risks posed by the consequences of climatic change and increase agricultural producers' resilience.

Under this category, you can find technologies and practices aiming at mitigating and adapting to climate change and natural hazards and disasters, including changing rainfall patterns, drought, floods, storms, landslides or wildfire and the geographical redistribution of pests and diseases. Practices that strengthen the resilience of agriculture and its people against natural hazards include the introduction of new varieties, specific constructions, crop diversification, alternative farming practices, among others.

Many, resilience-enhancing technologies and practices support social and community use of resources.

The climate change adaptation and disaster risk reduction category covers the Sustainable Development Goals of no poverty, zero hunger, industry, innovation and infrastructure, sustainable cities and communities, responsible consumption and production, climate action, life below water as well as life and land.

On the FAO-TECA platform, there are currently 174 technologies and practices within this category: 118 in English, 34 in Spanish, 15 in French and 7 in Portuguese.



4 Rainwater harvesting systems for cabbage growing in Uganda

Summary

This technology describes utilizing rooftop water harvesting facilities to increase the availability of water for domestic use and irrigation of backyard cabbage gardens. This measure allows small-scale farmers to harvest rainwater from roofs and store it in tanks, ensuring cabbage production even during the dry season.

The combination of rainwater harvesting with other good practices (e.g. mulching, manuring) help increase productivity while reducing soil erosion, eventually strengthening the resilience of farmers to the impact of dry spells.

Description

1. Suitability

This measure was tested by households in rural districts in Uganda facing frequent water shortages. Rainwater harvested in tanks can be used for domestic purposes and to water cabbage gardens requiring little water to produce decent yields.

If harvested water is managed carefully, it can be a reliable and significant water source during the dry season. Housing with an iron roof would have an advantage in installing water harvesting tanks as it facilitates the collection of rainwater.

2. Composition and types of tank

Rainwater can be harvested from roofs by building gutters that guide the water into a harvesting tank (Figure 1). Water can also be harvested by putting inclined iron sheets directly on the tanks, in addition to the roofs (Figure 1, bottom).

The water is then accessed with a pump (Figure 2). Several sizes of tanks were observed in the field, such as 7 000 litres; 30 000 litres; and 50 000 litres (Figure 3). The tank size depends on the needs, investment capacity of the farmer/community and the size of dwellings (medium sized tanks may be suitable for a dwelling that have a roof size greater than 25 m²).

Figure 1: Rooftop rainwater harvesting with gutter and tank



3. Major costs

At the point of writing the cost for establishing a tank system for rainwater harvest were as follows:

- 7 000 litre tank, UGX 2.3 million (USD 766 590);
- 30 000 litre tank with an inclined iron sheet, UGX 3.5 million (USD 1.17 million);
- 50 000 litre tank (compare Figure 3) costs UGX 4 million (USD 1.33 million); and
- Electronic pump (see Figure 2 for fuel pump) costs UGX 60 000 (USD 19 998).



4. Effectiveness and benefits

4.1 Socio-economic and ecological benefits

4.1.1 Shortterm benefits

- Saving time: water harvesting tanks give people easy access to water for domestic use and prevent them from walking long distances or queuing.
- Saving labour: instead of getting water, people will be available to do other tasks, e.g. working/attending school.
- Additional income: water can be sold at UGX 1 000 (USD 33.3) per jerry can.

4.1.2 Medium-term benefits

- An additional source of good quality water since other sources are polluted or depleted.

4.1.3 Long-term benefits

- Prevent water depletion from natural sources (groundwater, lakes, streams, swamp, etc.).
- Decrease erosion from surface run-off induced by heavy rains.

Figure 2: Pump to access water from the tank



4.2 Gender and related benefits

Women are usually responsible for harvesting water. Hence, these techniques allow women to save time that can be used instead to produce food and/or to go to school. Rainwater harvesting can, therefore, have significant benefits for women and contribute to gender equality.

4.3 Climate Change Adaptation-related benefits

Rainwater harvesting saves time and labour, provides an additional good source of water, helps to reduce erosion from heavy rains and limits water resource depletion, which is particularly important in a context of climate change where water resources are likely to become scarcer. Rainwater harvesting, therefore, offers opportunities to better adapt to climate change.

5. Side effects

Water harvesting tanks can have some negative side effects. If they are poorly constructed, the tanks can suffer from algae growth and pest invasion. They can also become a breeding ground for disease vectors if not properly maintained.

6. Major Barriers

There are usually no cultural or social barriers against water harvesting tanks. However, very often communities face financial challenges to buy the tanks and sometimes technical challenges to build the related harvesting infrastructure.

7. Synergies

Rainwater harvesting can create synergies with other adaptation options such as:

- low-cost drip irrigation systems;
- water harvesting rock embankment;
- valley dams; and
- use of mulch and compost to increase water retention capacity of the soil and reduce evaporation.

8. Cumulative net benefits and benefit-cost ratios of good practice and local practice

Cost-Benefit Analyses were conducted based on quantitative data collected during the monitoring period in the 2016 dry season



Figure 3: Rooftop rainwater harvesting with elevated tank



© FAO/Benedicte Kurzen

(Jun-Aug). Cumulative net benefits and benefit-cost ratios were calculated over 11 years per m² of cabbage garden.

Data collected from good practice plots were compared with data collected from local practice plots where no rainwater harvesting facilities were installed. For good practice plots, the gross value of production is calculated considering that farms produce cabbages throughout the year (except for the first year when the first six months are dedicated to installing the rainwater harvesting facility), while in local practice plots production is only possible during rainy seasons (6 months per year). Also, access to credit is key to ensure that farmers are able to invest in this good practice.

Given the small size of the sample analysed, additional research would be needed to confirm the results.

Figure 4: Chart of cumulative net present value per square meter over 11 years



Source: FAO 2018



9. Validation

9.1 The geographical area of practice validation

The practice was tested in Mubende and Nakasongola districts in Uganda. All farms were affected by dry spells during the monitoring period 2016 dry season (June to August). Rainfall was between 50 to 100 percent below normal in August, and land surface temperatures were 3 to 7 °C above average, reducing water availability.

9.2 Farmers' perception

The farmers interviewed for the evaluation of this good practice said they would replicate the good practice because they were able to grow vegetables also during the dry season. According to them, the practice helped increase production and income, while reducing work efforts to collect water. The farmers rated the good practice 5 out of 5 regarding its performance in the face of a dry spell.

10. Minimum requirements for successful implementation of the technology:

- inclined roof, preferably iron roof;
- ground space near the roof (approximately 6.5 square meters of space is needed to install a 7 000 litre tank);
- electricity for the pump if an electric pump is being installed; and
- initial financial investment to install the rainwater harvesting system (approximately USD 0.75 per m² of the plot).

Further reading

FAO. 2012. Project Document: Global Climate Change Alliance (GCCA) - Uganda: Agriculture Adaptation to Climate Change. Republic of Uganda. 44 pp.

Source: FAO



Crop Production



Crop production is concerned with growing crops for use as fibre and food.

This category includes practices and technologies ranging from pre-installation methods (e.g. soil preparation, instructions for construction, seed selection) to general management practices (e.g. sowing, planting, transplanting, weeding, pest and disease control, irrigation) and harvest.

Crops include grains and cereals, sugarcane, as well as legumes, oilseeds, vegetables, stimulants (e.g. coffee, tobacco), fibrous crops (e.g. cotton), tuberous roots (e.g. cassava, potatoes), fruits, forage (e.g. calliandra) and many others. Information on integrated cropping systems is also available.

In addition, you can find practices and organizational techniques in the field of crop production for social and economic community use of resources.

The crop production category covers the Sustainable Development Goals of no poverty, zero hunger, responsible consumption and production as well as life and land.

On the FAO-TECA platform, there are currently 403 technologies and practices within this category: 231 in English, 79 in Spanish, 50 in French and 43 in Portuguese.



5 Indoor oyster mushroom cultivation for livelihood diversification and increased resilience in Uganda

Summary

This practice describes indoor mushroom (*Pleurotus spp.*) cultivation as a means to diversify livelihoods and strengthen the resilience of farmers in Uganda. Indoor mushroom cultivation was promoted by the Global Climate Change Alliance (GCCA) project on Agriculture Adaptation to Climate Change in the central cattle corridor of Uganda.

Mushrooms can be grown at very low cost and in a relatively short time. It is a practice that can be adopted by small-scale farmers to diversify their income during the dry season, when lack of water may challenge the cultivation of other crops, and reduce their vulnerability to adverse weather. Indeed, mushroom production is done indoor, and it requires little amounts of water compared to other crops.

Description

1. Steps describing how to cultivate mushroom indoors

1.1 Mushroom spawns

Mushrooms are grown in 'gardens' where the spawns are inoculated. The spawns are filled into sterile glass bottles through a process that requires specific tools and knowledge. Farmers can either

buy mushroom spawns from specialized producers at local markets or be trained for producing mushroom spawns themselves.

Figure 1: Mushroom spawns in a sterile bottle



1.2 Substrate

Agricultural waste (e.g. from sorghum, millet, beans, peas, wheat, maize, etc.) or cotton waste can be used as a substrate to grow oyster mushrooms. The agricultural waste, which is easily available on farms, is soaked for three days and then heaped for fermentation for four to six days in a closed container.

After the fermentation process, the agricultural waste is sterilized through boiling in closed pots for 12 hours in order to eliminate unwanted organisms and bacteria. After cooling, it is filled in small polyethylene plastic bags using common bowls, to serve as a substrate. The substrate should be composed by 65 to 75 percent of moisture, and for the remaining part by agricultural waste. It can be used for three harvests, and then it can be recycled as organic mulch or fertilizer. Alternatively, cottonseed waste can be used as a substrate for the oyster mushroom production.



Figure 2: Agricultural waste being soaked



1.3 Inoculation

Polyethylene plastic bags are filled with the substrate (about 5 kg per bag), which is then inoculated with the mushroom spawns (spawns are 'mixed' with the substrate). Each garden of about 5 kg of the substrate is filled with about 250 g of spawns. Then, the plastic bags are closed manually.

Figure 3: Plastic bags are being filled before inoculation



1.4 Incubation

Following the inoculation process, the mushroom bags are hung in locally built (brick or mud walls and thatched roof), darkened mushroom houses for incubation. The ideal humidity of the incubation room is 70 to 75 percent. Each room can host up to 300 gardens.

Figure 4: Mushroom house





1.5 Harvest

The mushrooms start sprouting after about 28 to 35 days from inoculation. Each mushroom garden (i.e. plastic bag containing about 5 kg of substrate) yields a minimum of 2 kg of fresh oyster mushrooms.

1.6 Drying and packing

Harvested mushrooms can be sold fresh, or they can be dried in a solar dryer and packed into plastic bags for sale.

2. Major costs and resources needed to cultivate oyster mushrooms

The approximate production costs per average mushroom garden (about 5 kg of substrate) yielding about 2 kg of fresh mushrooms are the following:

- cost of polyethylene bag: UGX 25 (USD 0.007) per bag;
- cottonseed waste: UGX 7 000 (USD 1.92);
- mushroom spawns: UGX 3 000 (USD 0.82); and
- labour: UGX 115 (USD 0.03).

2.1 The approximate upfront capital costs required to start mushroom production are the following:

- growing room: UGX 800 000 (USD 219.12); and
- solar dryer: UGX 700 000 (USD 191.73).

2.2 Mushroom market prices:

- dried mushroom: UGX 30 000 (USD 8.22) per kg; and
- fresh mushroom: UGX 8 000 (USD 2.19) per kg.

The costs, prices and exchange rates mentioned in this practice refer to the time of writing (May 2017).

3. Cost-Benefit Analysis of the practice

The performance of indoor mushroom cultivation was assessed at farm-level in Uganda. The net benefits obtained from producing mushroom in the central cattle corridor of Uganda were calculated through a cost-benefit analysis (CBA).

The CBA calculates the net present value (NPV) of cumulative benefits obtained from an average mushroom house over a period of 11 years (10 percent discount rate is applied to express the future value of costs and benefits in present terms), as well as the benefit-cost ratio (BCR), which is the ratio between total discounted benefits and

Figure 5: Mushrooms sprouting in the growing room





total discounted costs over the appraisal period. Since mushroom cultivation was not previously practised in the monitored farms, control plots were not available to conduct a comparative analysis. As an alternative, the opportunity cost of agricultural labour was used, i.e. the income foregone by not employing the labour used for mushroom production elsewhere.

Figure 7 and Figure 8 provide an overview of the outcome of the CBA. In particular, it shows that:

- In dry spell conditions (Figure 7), the net benefit of mushroom growing over 11 years is more than seven times higher than the opportunity cost of labour. The BCR in dry spell conditions is 4.7.
- In non-hazard conditions (Figure 8), the net benefits from mushroom growing are more than nine times higher than the opportunity cost of labour. Mushroom growing in non-hazard conditions brings USD 5.3 per each US dollar invested.

These results show that mushroom production is an effective livelihood diversification practice. Under the opportunity cost scenario, it is assumed

that all labour (including family labour) needed for mushroom production would be absorbed by the local agricultural labour market otherwise. Under dry spell conditions, however, it is reasonable to expect that agricultural employment opportunities would be limited, thereby making mushroom growing an even more attractive option.

4. Socio-economic and ecological benefits

The sale of mushrooms in local markets provides an additional income source to farmers and strengthens food security of the most vulnerable rural households.

This is even more evident in dry seasons, when lack of water may challenge the production of other crops. Nine of the interviewed farmers (67 percent) found that the practice provided better and more diverse food to the family.

The limited work effort required to grow mushrooms makes this practice accessible to men, women, the elderly, as well as people with disabilities. In Uganda, women play a central role in mushroom production. Furthermore, mushroom cultivation uses a limited amount of natural resources such

Figure 6: Solar dryers for mushrooms





Figure 7: Cumulative Net Benefits and Benefit-Cost Ratio of mushroom cultivation as compared to the opportunity cost of labour in farms affected by dry spell, 2016-2026



Source: FAO 2017

as water and land, compared to other crops cultivated in the area.

5. Disaster Risk Reduction and Climate Change Adaptation-related benefits

Since indoor mushroom cultivation requires a limited amount of water compared to other crops, this practice contributes to Disaster Risk Reduction and Climate Change Adaptation in dry areas where decreasing average rainfall may lead to more frequent and more prolonged dry spells.

6. Difficulties and/or limitations

Three beneficiary farmers (out of 14) expressed concerns regarding access to inputs. In particular, mushroom spawns should be made available in local markets to maximize the benefits of this practice

7. The geographical area of practice validation

The practice was validated and implemented in the central cattle corridor of Uganda. In particular, farmers started growing

Figure 8: Cumulative Net Benefits and Benefit-Cost Ratio of mushroom cultivation as compared to the opportunity cost of labour in non-hazard conditions, 2016-2026



Source: FAO 2017

oyster mushrooms in addition to common crops in the districts of Kiboga, Mubende, Sembabule, Nakaseke, and Nakasongola.

8. Context of implementation

This practice was validated and introduced by the Global Climate Change Alliance (GCCA) project on Agriculture Adaptation to Climate Change in Uganda. All interviewed farmers (14 households) said they would continue to implement the good practice since it increased resilience and provided additional food to the family. Farmers said that there is a demand for mushrooms in the area, and they are generally able to sell mushroom (dried or fresh) in local markets.

However, it is possible that the activities required for mushroom production are conflicting with work in the field.

8.1 Environmental and climatic (period/season) context

The performance of the good practice was monitored over a three months



period during the 2016 dry season (June to August). Most farms were affected by dry spells during the monitoring period. In particular, rainfall was between 50 percent to 100 percent below normal in August, and land surface temperatures were 3 to 7 °C above average, causing a reduction in water availability.

8.2 Social–target group

Smallholder farmers.

9. Necessary basic conditions for a successful implementation

A warm and humid climate is suitable for indoor oyster mushroom cultivation. The

existence of a demand for mushrooms is key to ensure the success of the practice.

10. Constraints (limiting factors) for the implementation of the technology

No major barriers were identified except the availability of mushroom spawns in local markets.

Source: FAO

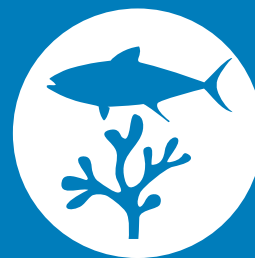

Fishery and Aquaculture



The category fishery and aquaculture covers the wild capture and farming of aquatic organisms including fish, molluscs, crustaceans and aquatic plants. This category includes practices and technologies on sweet and saltwater fish species, in particular on stock management, fishing techniques and its limitations, and fishing equipment.

Technologies and practices on aquaculture species, e.g. different fish species, shrimp/prawns, and seaweed, range from pond construction to breeding, feeding, and fish health control as well as pond management, and harvesting. For both fishery and aquaculture, there are technologies on post-harvesting methods (e.g. storage, processing, and marketing).

It also includes information on the construction and management of aquaponics, a bio-integrated system that links recirculating aquaculture with hydroponic vegetable, flower, and/or herb production.

In addition, you can find practices and organizational techniques in the field of fishery and aquaculture for social and economic community use.

The fishery and aquaculture category covers the Sustainable Development Goals of no poverty, zero hunger, responsible consumption and production as well as life below water.

On the FAO-TECA platform, there are currently 57 technologies and practices within this category: 49 in English, 1 in Spanish and 7 in French.



6 Deep Water Culture Aquaponic Unit: Step by Step Description

Summary

Aquaponics is the integration of recirculating aquaculture and hydroponics in one production system. The Deep Water Culture (DWC) is one of the three common methods of aquaponics being utilized at present, generally implemented at large-scale operations.

This technology provides a detailed explanation of the main components of this method and a step by step guide to constructing a DWC.

Description

In a deep water culture method, also known as the raft method or floating system, the nutrient-rich water is circulated through long canals at a depth of about 20 cm while rafts (usually polystyrene) float on top.

Plants are supported within holes in the rafts by net pots. The plant roots hang down in the nutrient-rich, oxygenated water, where they absorb large amounts of oxygen and nutrients which contribute to rapid growth conditions.

This method is the most common for large commercial aquaponics growing one specific crop (typically lettuce, salad leaves or basil) and having high stocking density of fish (up to 10 and 20 kg of fish per cubic meter of the fish tank). However, it can be adapted to a low stocking density of fish production.

1. Components of the Deep Water Culture Aquaponic Unit (DWC)

1.1 Water flow

In the deep water culture unit described in this technology, water flows by gravity from the fish tank, through the mechanical filter, and into the combination biofilter/sump. From the sump, the water is pumped in two directions through a (Y) connector and valves. Some water is pumped directly back to the fish tank.

The remaining water is pumped into the manifold, which distributes the water equivalently through the canals. The water flows, again by gravity, through the grow canals where the plants are located and exits on the far side. On exiting the canals, the water is returned to the biofilter/sump, where again it is pumped either into the fish tank or canals. The water that enters the fish tank causes the fish tank to overflow through the exit pipe and back into the mechanical filter, thus completing the cycle.

The flow rate of the water entering each canal is relatively low. Generally, every canal has 1 to 4 hours of retention time. Retention time is a similar concept to turnover rate and refers to the amount of time it takes to replace all the water in a container. For example, if the water volume of one canal is 600 litres and the flow rate of water entering the container is 300 litres/h, the retention time would be 2 hours (600 litres divided by 300 litres/h).

However, when a low stocking density of fish (i.e. 1 to 5 kg of fish per one cubic meter of the fish tank) is used, the DWC can be designed without using external filtration containers, mechanical or biological.



Figure 1: Water flow diagram

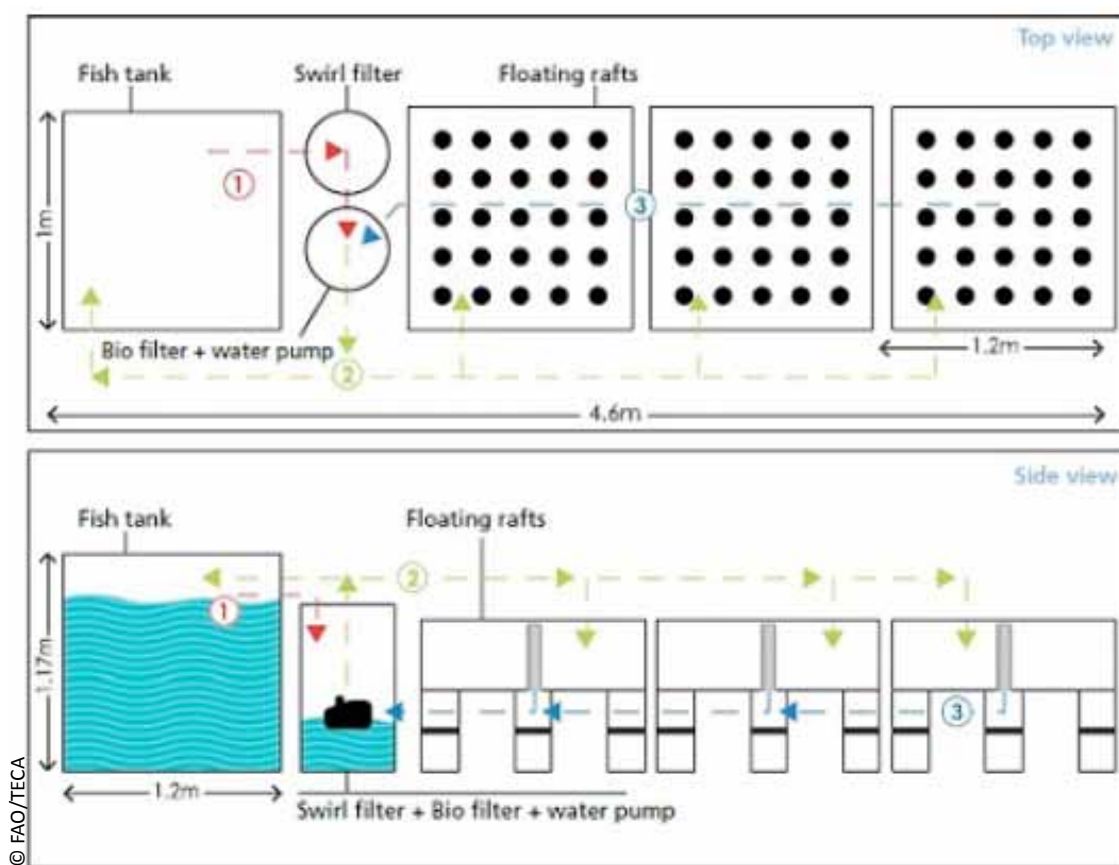

In this system, water flows by gravity from the fish tank straight into DWC canals, passing through a very simple mesh screen. Water is then returned either to a sump and pumped back to the fish tanks, or directly to the fish tanks without a sump. Water in both the fish tanks and canals is aerated using an air pump. The fish waste is broken down by nitrifying and mineralizing bacteria living on the plant root surface and the canal walls. To procure additional mineralization and biofiltration, and to avoid waste accumulation of solids at the bottom of the canals, a simple mesh screen with a basket of pea gravel or clay balls can be positioned just above the water level where the water exits the fish tank.

1.2 Filtration

Two types of filters need to be constructed using the first technique: first, a physical trap to catch the solid wastes, and then a biological filter for nitrification. The designs described in this publication use a mechanical swirl filter to trap particulate wastes, with periodic venting of the captured solids. On exiting the swirl filter, the water passes through an additional mesh screen to trap any remaining solids and then reaches the biofilter. The biofilter is well oxygenated with air stones and contains a biofiltration media, usually Bioballs®, nylon netting or bottle caps, where the nitrifying bacteria transform the dissolved wastes.



With insufficient filtration, the DWC units would clog, become anoxic and exhibit poor growing conditions for plants and fish alike. When a stocking density of fish is used, the system can be designed without filters, as described in the previous section.

1.3 DWC grow canals

Canals can be of variable lengths, from one to tens of metres, enabling an adequate nutrient supply due to the large volume of water used in this system. As far as the width is concerned, it is generally recommended to be the standard width of a sheet of polystyrene, but it can be multiples of this.

However, narrower and longer canals enable a higher water speed that can beneficially hit the roots with larger flows of nutrients. The choice of width should also consider accessibility by the operator. The recommended depth is 30 cm to allow for adequate plant root space.

Similar to fish tanks, canals can be made out of any strong, inert material that can hold water. For small-scale units, popular materials include fabricated Intermediate bulk containers (IBC) plastic containers or fibreglass. Much larger canals can be constructed using wood lengths or concrete blocks lined with food-grade waterproof sheeting. If using concrete, make sure it is sealed with non-toxic, waterproof sealer to avoid potential toxic minerals leaching from the concrete into the system water. The retention time for each canal in a unit is 1 to 4 hours, regardless of the actual canal size.

This allows for adequate replenishment of nutrients in each canal. Plant growth will definitely benefit from faster flow rates and turbulent water because roots will be hit by many more ions; whereas slower

flows and almost stagnant water would have a negative impact on plant growth. Aeration for DWC units is vital. In a densely planted canal, the oxygen demand by the plants can cause dissolved oxygen (DO) levels to plummet below the minimum. Any decomposing solid waste present in the canal would exacerbate this problem, further diminishing DO.

Thus, aeration is required. The simplest method is to place several small air stones in the canals. The air stones should release about 4 litres of air per minute, and be arranged every 2 to 4 square meter of canal area. In addition, Venturi syphons can be added to the water inflow pipes to aerate the water as it enters the canal.

Finally, the Kratky method of DWC can be used, which consists in leaving a space of 3 to 4 cm between the polystyrene and the water body inside the canal. This allows air to circulate around the top section of the plant roots. This approach removes the need for air stones in the canal as sufficient amounts of oxygen in the air are supplied to the roots.

Another advantage of this method is the avoidance of direct contact of the plant stems with water, which reduces the risks of plant diseases in the collar zone. Moreover, the increased ventilation as a result of the increased airspace favours heat dissipation from water, which is ideal in hot climates.

Do not add any fish into the canals that could eat the plant roots, e.g. herbivorous fish such as tilapia and carp. However, some small carnivorous fish species, such as guppies, mollies, or mosquito fish, can be used successfully to manage mosquito larvae, which can become a huge nuisance to workers and neighbours in some areas.



2. Planting in a DWC unit

As mentioned previously, this method involves suspending plants in polystyrene sheets, with their roots hanging down into the water. The polystyrene sheets should have a certain number of holes drilled to fit the net cups (or sponge cubes) used for supporting each plant. The amount and location of the holes are dictated by the vegetable type and the distance desired between the plants, where smaller plants can be spaced more closely.

Seedlings can be started in a dedicated plant nursery in soil blocks or a soilless medium. Once these seedlings are large enough to handle, they can be transferred into net cups and planted into the DWC unit.

The remaining space in the net cup should be filled with hydroponic media, such as volcanic gravel, rockwool or Lightweight Expanded Clay Aggregate (LECA), to support the seedling. It is also possible to simply

plant a seed straight into the net cups on top of the media. This method is sometimes recommended if vegetable seeds are accessible because it avoids the transplant shock during replanting.

When harvesting, be sure to remove the whole plant, including roots and dead leaves, from the canal. After harvest, the rafts should be cleaned but not left to dry so as to avoid killing the nitrifying bacteria on the submerged surface of the raft.

Large-scale units should clean the rafts with water to remove dirt and plant residues and immediately repositioned in the canals to avoid any stress to the nitrifying bacteria.

3. Step by Step guide to constructing a DWC unit

3.1 Preparing the fish tank

Please follow the same procedures described in the TECA Media Bed Aquaponic Unit (Section 1 and 2).

Figure 2: Fish tank and concrete blocks placement





3.2 Preparing the mechanical separator and biofilter

Please follow the same procedures described in the TECA Nutrient Film Technique (Section 1-4).

3.3 Making three DWC canals from two IBC Tanks

Please follow the same procedures described in the TECA Media Bed Aquaponic Unit (Section 4)

3.4 Initial steps in building a DWC system

Follow the steps contained in the previous sections to set up the fish tank, the mechanical separator, the biofilter and three DWC canals from two IBCs. Once completed, proceed to assemble the DWC canals. For the DWC system, the cut IBC bed used as a sump tank in the media bed unit can be used as the forth canal. Extra blocks and plumbing are required to install the forth canal.

3.5 Assembling the DWC canals

Place the concrete blocks according to the distances described in Figure 11.2:1a. The fish tank should be raised up about 15 cm; do so by using concrete blocks. Then, place

the three grow beds (including the metal support frames) on top of the blocks as shown in Figure 2:1b. (Make sure the grow beds are secure on top of the blocks. If not, slightly adjust the layout of the blocks underneath).

3.6 Preparing the drainage pipes into the biofilter

The following materials are needed to make three drainage pipe units:

- 24 cm of PVC pipe (25 mm) x 3;
- Barrel connectors (25 mm) x 3;
- PVC adaptor, female (1 inch – 25 mm) x 3;
- PVC elbow, female (1 inch – 25 mm) x 1;
- PVC T–connector (25 mm – 1 inch [female] – 25 mm); and
- Rubber washer (25 mm).

Take each DWC canal and mark their centre points at the bottom of the canal. Drill a 25 mm diameter hole at each centre point and insert the 25 mm barrel connector (25 mm) with the rubber washer placed inside the grow bed. Tighten both sides of the connector using a wrench (see Figures 3: 2-4). Screw the PVC adaptor, female (1 inch – 25 mm) on to the barrel connector (25 mm) inside the tanks and then slot the

Figure 3: Drilling location on the barrel





standpipe into the adapter. Make sure to cut five longitudinal slots on the upper end of the standpipe to prevent the pipe from clogging (Figures 4: 5–6).

Next, connect the PVC elbow, female (25 mm – 1 inch) to the end of the barrel connector underneath the DWC canal that is farthest from the fish tank (Figures 5: 7–10). Then fix the remaining two PVC T-connectors (25 mm – 1 inch [female] – 25 mm) to the barrel connectors underneath the other two canals.

Take three pieces, every 1 m in length, of PVC pipe (25 mm) and connect the elbow to the two T-connectors underneath the canals (Figures 6: 11–12).

Finally, drill a 25 mm hole into the side of the biofilter barrel using the circular drill bit at least 15 cm below the standpipe height in the canals and insert a barrel connector (1 inch) in it. Then, connect a PVC elbow (25 mm – 1 inch) to the barrel connector and then take one more piece of PVC pipe (25 mm) and connect the PVC elbow

Figure 4: PVC adapter connected to the barrel connector

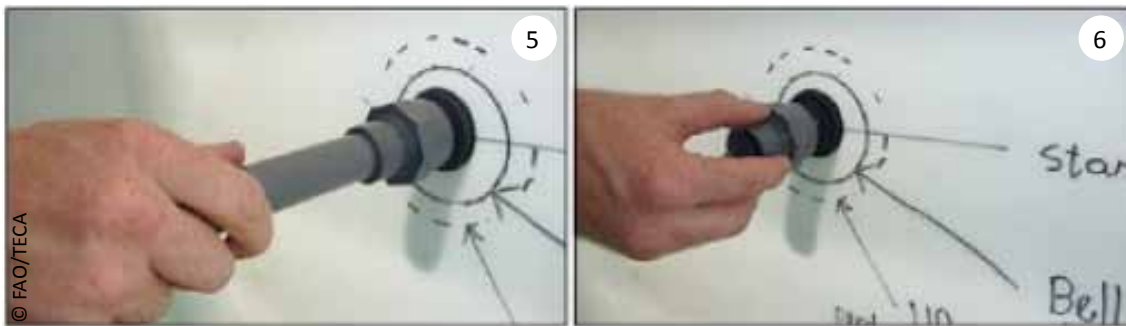

Figure 5: PVC elbow connection

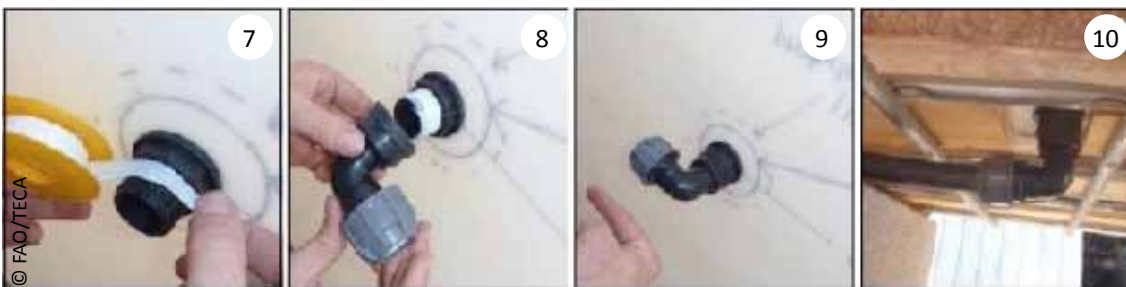

Figure 6: Connection between canals A, B and C





Figure 7: Connections between the tanks

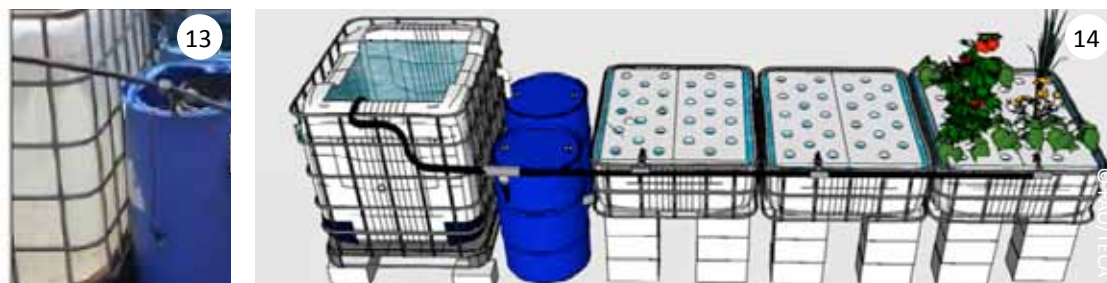

Figure 8: the Submersible pump is placed at the bottom of the biofilter barrel



(25 mm – 1 inch) where it exits the biofilter to the final T-connector underneath the tank A and slot the other into the 25 mm hole in the biofilter (Figures 7: 13–14).

Figure 9: T-connector



3.7 Adding the submersible pump

For this unit, the submersible pump is placed at the bottom of the biofilter barrel (Figures 8: 15–16). Water is pumped from there into two locations: the three DWC canals and the fish tank. 80 percent of

the water flows to the fish tank while 20 percent flows into the plant canals. The taps are used to control the water flow at each location (Figure 9: 17).

3.8 Pumping to the fish tank and DWC canals

Connect the submersible pump to a length of polyethylene pipe (25 mm) pipe length using an adaptor (1 inch female – 25 mm), or any other connection that fits the pump. The pipe should be at least 1 m long. Place a T-connection (25 mm) at the end of the pipe allowing water to flow to the fish tank and the canals (Figure 10: 18). Attach a pipe (25 mm) to one end of the T-connection long enough to reach the fish tank. Use flexible pipe if possible as this removes the need for elbow connections, which reduce the pumping capacity of the pump (Figure 10: 19). Attach a tap (25 mm) to the end of the pipe to control the water flow into the fish tank. Next, take about



Figure 10: T-connector connecting the fish tank with the canal



Figure 11: Water flow into each canal



Figure 12: Connect the pipes to the metal frame with plastic cable ties





3.5 m of polyethylene pipe (25 mm) and attach one end to the remaining exit of the T-connection (25 mm) coming from the pump in the biofilter. Then, take the 3.5 m pipe and lay it along the DWC canals. At each canal, add a T-connector (25 mm – three-quarter inch – 25 mm), a tap (three-quarter inch male – three-quarter inch female), and a PVC elbow (25 mm – inch male) allowing water to flow into each canal at an angle (Figures 11: 20–22). At the final canal furthest from the fish tank using a PVC elbow (25 mm – three-quarter inch female) instead of the T-connector. Be sure to secure the pipes to the metal frame by means of plastic cable ties.

3.9 Installing the air pump and stones

For this unit, the air pump is used to integrate air into the DWC canals. The air pump should be placed into a protected box at the highest point in the system (ideally attached to the side of the fish tank) (Figure 12: 25).

Take 4 to 6 m of 8 mm air pipe. Attach one end to the air pump and lay the rest of the 8 mm pipe along the side of all the DWC canals. On each tank, drill an 8 mm hole just below (1 to 2 cm) the top and slot the 8 mm pipe into each hole.

Attach the air stones to the 8 mm pipe and place them next to the inlet water stream to

Figure 13: Planting hole size



Figure 14: Polystyrene cutting and placement



Figure 15: Plant holes preparation

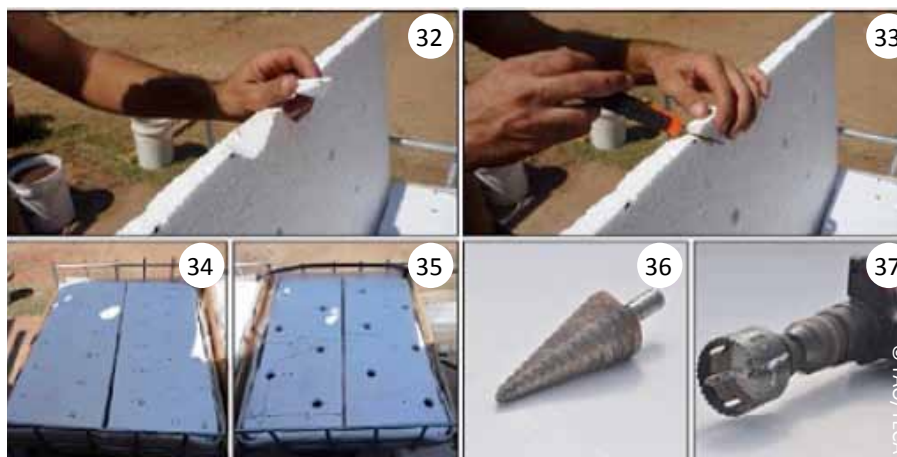



ensure full oxygen saturation in the canal. Repeat the same air pipe connection for the fish tank (Figures 12: 23, 24 and 26).

3.10 Making the rafts

- Key principles and rules of thumb for making the polystyrene rafts: All water in the canals should be fully covered (no exposure to light).
- Choose polystyrene sheets that are at least 3 cm thick to hold the weight of the vegetables.
- The polystyrene must not release any toxins to the water (make sure it is safe for food production or food-grade

quality). Painted plywood can also be used.

- Plant hole sizes and spacing are dependent on the type of vegetables to be planted.
- The planting hole size can range from 16 mm (for planting seedlings directly into the rafts without cups (Figure 13: 28)) to 30 mm. This depends on the size of the net cups available (Figure 13: 27).

Place the polystyrene on top of the DWC canals and mark the edge lines. With a knife, cut the outline of the canal

Figure 16: Fish tank filled with water



Figure 17: Secure pipes with plastic cable





Figure 18: Planting process with cups

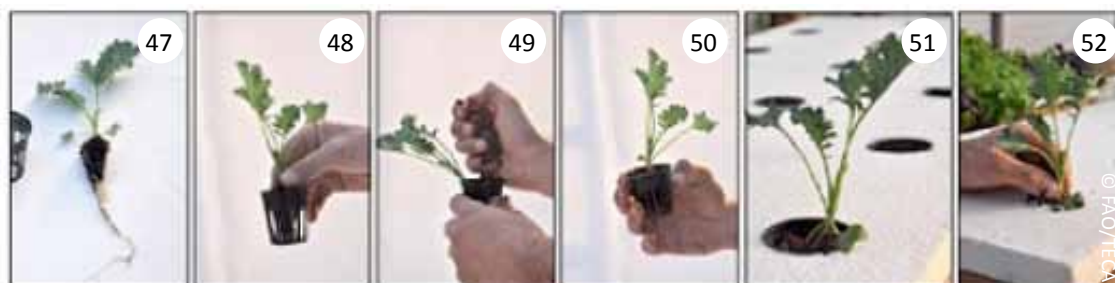

Figure 19: Finished system



(Figures 14: 29–31). Drill the plant holes (Figures 15: 34–35) using a circular drill bit (Figures 15: 36–37). Along with planting holes, make sure to cut one hole for the standpipe of each canal (Figures 15: 32–33).

3.11 Final checks

Once all parts of the system are in place, fill the fish tank, both filters and DWC canals (Figures 16: 38–43) with water and run the pump to check for any leaks in the system. If leaks appear, fix them immediately where they arise by:

- tightening the plumbing connections;
- checking all uniseals and taps for both filters;
- reapplying Teflon to threaded connections; and
- making sure all valves are in their ideal position.

Secure all the remaining pipes with plastic cable ties (Figures 17: 45–46).

Finally, check the flow rates of the water flowing into each DWC canal. Knowing that the volume of each canal is about 300 litres, the ideal flow rate for each canal should be 75 to 300 litres per hour.

Water inflow can be measured by using a stopwatch and an empty 1-litre plastic bottle (Figure 17: 44). At 75 litres/hour the 1-litre bottle should fill up in 48 seconds, at 300 litres/hour in 12 seconds.

Once all the leaks are fixed, and the water is flowing through all components of the unit, begin cycling the unit by using ammonia to stimulate nitrifying bacteria colonization.

Planting process with (Figures 18: 47–51) and without cups (Figure 18: 52).



This technology is part of a series on other TECA technologies and practices about Aquaponic units:

- Designing an Aquaponic unit;
- Media Bed Aquaponic Unit – Step by Step Description;
- Nutrient Film Aquaponic Unit – Step by Step Description; and
- Deep Water Culture Aquaponic Unit – Step by Step Description 5. Management of the Aquaponic Systems.

Further reading

FAO. 2014. Small-scale aquaponic food production - Integrated fish and plant farming. <http://www.fao.org/3/a-i4021e.pdf>

FAO. 2015. 7 rules-of-thumb to follow in aquaponics. <http://www.fao.org/zhc/detail-events/en/c/320156/>

Source: Fisheries FAO



Forestry



Forestry is understood as the “science and craft of creating, managing, using, conserving, and repairing forests, woodlands, and associated resources to meet desired goals, needs, and values for human and environmental benefits” (Dictionary of forestry).

Sustainable management of both spontaneous and planted forests requires good management practices, including careful breeding and site selection, the management of tree nurseries, plantation and propagation of trees, as well as forest health management and harvesting. Planted forests include bamboo, rattan, and sago palms among others.

Under the forestry category, you can find technologies and practices on the planting and managing of forests as well as the processing of forestry products and their marketing. In addition, you can find practices and organizational techniques in the field of (agro)forestry for social and economic community use of resources.

The forestry category covers the Sustainable Development Goals of zero hunger, responsible consumption and production, climate action as well as life and land.

On the FAO-TECA platform, there are currently 68 technologies and practices within this category: 43 in English, 8 in Spanish, 13 in French and 4 in Portuguese.



7 Evergreen Agriculture: Conservation Agriculture in maize production in Malawi

Summary

Evergreen Agriculture is a combination of conservation agriculture and agroforestry practices within the same spatial and temporal dimensions. In other circles, evergreen agriculture is referred to as agroforestry-based conservation agriculture or Conservation Agriculture With Trees (CAWT). Evergreen agriculture is being tested by the World Agroforestry Centre (ICRAF) in conjunction with partners in Malawi, and across Africa as a means for enhancing soil fertility, increasing crop productivity and increasing food production.

This section will focus on the principles and practices of Conservation Agriculture (CA) as applied in maize production in Malawi. Conservation agriculture also improves the soil health and productivity as well as the crop production. ICRAF envisages that a combination of conservation agriculture and agroforestry practices together with other technologies will improve soil health and improve crop production and, finally, food security in Malawi.

Description

Conservation agriculture employs the judicious use of conservation tillage, mulching and integrating of main crops with legume crops and/or trees to conserve natural resources, soil and water for improved and sustainable production.

Conservation tillage is the core principle of conservation agriculture as it distinguishes the new tillage system from the predominant ridge-based tillage system. It is particularly crucial in the social dynamics of tillage practices because the burning of crop residues and ridging is strongly engraved in the social fabric of smallholder agriculture in Malawi. It requires a systematic transformation of the mindset of smallholder farmers towards perceiving conservation tillage as an economically viable, ecologically sustainable and smallholder friendly practice.

1. Principles and benefits of conservation tillage

Conservation tillage entails reducing tillage operations to the minimum required to plant crops. In Malawi, this tillage would involve scratching or ripping out the soil where the crop is to be planted and leaving the rest of the land untilled until weeding is required. Alternatively, conservation tillage can be done by constructing planting basins where seeding would take place. Conservation agriculture enhances natural ecological processes to conserve moisture by improving water infiltration, enhance soil fertility and improve soil structure. Conservation agriculture also reduces soil erosion and the emergence of pests and diseases.

Conservation agriculture is a combined application of three non-negotiable principles, which are:

- minimum soil disturbance;
- maximum soil cover; and
- crop associations and rotations.

1.1 Minimum soil disturbance

The tendency of splitting old and forming new ridges year by year is very dominant among the smallholder farmers in Malawi. This type of tillage disturbs the soil so much



that it encourages soil erosion and loss of soil fertility. This key principle stipulates that a farmer should till the soil as little as possible. The numerous on-farm research works indicate that maize and other crops can still grow well in less tilled or un-ridged fields. This principle encourages farmers to disturb the soil wherever strategic inputs such as seed, fertilizer and manure are to be placed. Conservation agriculture promotes minimum disturbance in the range of 12 to 15 percent of the soil. Under conventional agricultural practices, tillage affects 100 percent of the soil. Minimum tillage overcomes many of the disadvantages of ridging. Ploughing and hoe ridging disturb soil layers and thereby destroy the structure of the soil. When the soil structure is destroyed, water infiltration and soil organic matter are disturbed. Low levels of organic matter render the soil less capable of retaining nutrients and water in the soil. In conventional tillage, ridges are seldom constructed across the slopes as recommended, hence further facilitating soil erosion and land degradation.

1.2 Maximum soil cover

1.2.1 Retaining residues

Conventional tillage systems encourage the clearing of crop and weed residues during land preparation. Once cleared, residues are burnt to control weeds, pests and diseases. However, the residues vanish with residual nutrients in their stalks, rendering nutrient cycling difficult. This burning of residues also predisposes the clear soil to run off by early heavy rains leading to soil erosion and land degradation. Due to the continuous clearing of residues and intense rain splash for a number of years, coupled with continuous hoeing, hoe hardpan is

created hindering root penetration and water infiltration severely. It is against this background that conservation tillage encourages the incorporation or spreading of crop residues. The residues are supposed to come from the same crop field unless otherwise. For instance, cotton and tobacco residues are commanded to be burnt to avoid the building up of sustaining pests and diseases. However, the fields which can be spread with tobacco and cotton residues can be rotated with other crops (See crop association section).

Residue management and challenges: In maize-based systems, the multiple uses of maize stover render them scarce and unavailable for farmers to cover their fields. In the southern region, maize stover is so scarce that farmers spread old grass thatch or combed grass on their crop fields. The maize stover, instead, is used for cooking and construction of fences due to the scarcity of firewood. In the central region, however, farmers use maize stover for fumigating tobacco seedbed nurseries and feeding livestock. They usually burn them when hunting for mice. In the northern region, the maize stover is also used for feeding livestock and fumigating tobacco seedbed nurseries. These geographical differences are potential challenges for scaling up conservation agriculture in Malawi. Also, there is a tendency that a farmer only possesses ownership rights on crop produce and loses them on crop residues. This attitude predisposes crop residues as open access resources, which can be utilized by any member of the community. It is a common practice in Malawi to see farmers feeding their livestock on other farmers' fields without any form of reciprocity. ICRAF



mobilized farmers through traditional leadership and extension workers to develop livestock bylaws to control free roaming of livestock during and after the growing season. Communities willing to practice conservation agriculture should be encouraged to manage their livestock properly to ensure maximum compatibility of conservation agriculture with livestock systems. The livestock, when well managed, would provide manure and draught power to conservation agriculture farmers.

The culture of heaping maize stalks with cobs for drying up and harvesting makes the work of spreading maize stover laborious to farmers. Conservation agriculture farmers usually tend to transport the stover to where the practice is being done and find this work tedious. Some farmers have commended the heaping practice because it secures their stover at one place and protects it from mice hunters and roaming livestock. Farmers can harvest their maize from the standing stalks, and the harvested stalks can be cut and laid down whilst harvesting the field. This reduces the double operation of taking away and bringing back maize stover. The only challenge with the early spreading of stover is roaming livestock and the lack of tenure over residues. If this improves, farmers find this practice doable and time and labour saving.

1.2.2 Spreading of soil cover

Farmers can use soil cover materials such as crop residues, old thatch grass and combed grass (e.g. removed flower heads). Caution should be used when farmers want to retain weed residues in the early stages of conservation agriculture. Most

weed residues have seeds, which infest the field as tillage will be minimized. The crop residues should be spread systematically around the planting basins and planting stations, which may be tasking for farmers in the first year of doing conservation agriculture. In the subsequent years, however, farmers will mark where the old maize stumps are, and crop residues will be spread around them. Studies are currently being conducted to determine the recommended amount of stover or soil cover at smallholder scale. It is envisaged that maize stover will soon be an economic commodity.

Benefits of maximum soil cover:

- Well-placed residues reduce the impact of rain splash and runoff. This checks soil erosion and land degradation.
- Residues promote biological activity by the soil fauna and flora. These activities facilitate the breakdown of residues into small particles that turn into hummus or soil organic carbon. The increased fauna activity improves nutrient cycling from the subsoil to topsoil.
- In termite-infested areas, the residues divert the attack on green growing maize to the decomposing stover or residues.
- Residues retain soil moisture by reducing evaporation and evapotranspiration. One farmer noted during ICRAF field days that conservation agriculture plots with a maximum of mulch had turbid leaves whilst non-mulched plots had withered leaves.
- Crop residues release trapped mineral nutrients in the stalks through mineralization and are made available to the roots of the main crop. This is cost effective, as it reduces the amount of fertilizer to be applied.



- Soil temperature is regulated by the crop residues which function as heat insulators. This promotes biological activity and reduces volatilization of mineral compounds from the soil.
- Soil aggregate stability and porosity increases.

1.2.3 Cover crops

Alternatively, cover crops are intercropped with main crops to serve the physical attributes of soil cover, biological nitrogen fixation and mineralization from the nitrogen-rich biomass. Although this could be classified as following the third principle of crop association or intercropping, it, however, needs to be emphasized that farmers who have problems of scarcity of maize stover and crop residues due to their multiple uses can use cover crops to attain maximum soil cover. The cover crops include cowpeas, velvet beans, soya beans and common beans. After harvesting the main crop, the cover crops should be well managed against livestock influence and fire incidences.

Intercropping with cover crops should be performed carefully. The recommended spacing for cover crops under intercrops should be followed to avoid light, space and nutrients competition between crops.

2. Forms of conservation tillage

Conservation agriculture is a very important cultural practice, and it varies from one place to another and one farmer to another. In Malawi, in the first year of practising conservation tillage, farmers have difficulties in planting maize in old ridges, which are usually infested with weeds. There is a chronic problem of weed infestation due to the poor weeding practices. When the main crop has reached physiological maturity, they let the weed to flower and shed off seeds

on and in the soil. This scares smallholder farmers of increased labour in weeding when they intend to practice conservation tillage. Despite extensive extension messages on the recommended ridge spacing to obtain recommended plant populations for maize systems, farmers have tended to construct either closer or wider planting ridges at 50 to 60 cm distance or 80 to 90 cm distance, respectively.

This also predisposes difficulties among farmers in using the right spacing during demonstrations. The planting of the next maize becomes difficult because the planting stations become both on the ridges and on the furrows. Since labour is generally a problem during land preparation and conservation agriculture is promoted as labour saving, it would not be wise to advise farmers to break the old ridges to start practising conservation agriculture.

2.1 Use of old ridges

Since no agro-ecological suitability studies have been conducted on conservation tillage in Malawi, the rule of thumb would be that farmers should be encouraged to use old ridges at previous ridge spacing to avoid breaking old ridges as doing so would be considered conventional tillage.

There are many non-governmental organizations (NGOs) that promote the use of old ridges in the early years in conservation agriculture. These include Total LandCare (TLC), National Smallholder Farmers Association of Malawi (NASFAM), Concern Universal, Development Aid from People to People (DAPP), Farm Income Diversification Programme (FIDP) and many others. ICRAF, in collaboration with NASFAM, the Catholic Relief Services (CRS) and TLC have been active in scaling up Evergreen Agriculture (agroforestry-based



conservation agriculture) in the Kasungu, Mchinji and Chiladzulu districts. Also, in cooperation with NASFAM, the Government of Malawi and the Lake Malawi Basin project, ICRAF is implementing an Alliance for a Green Revolution in Africa (AGRA) project on conservation agriculture in the Kasungu, Lilongwe and Salima districts.

Farm demonstrations were set up on the use of old ridges and other conservation agriculture practices, and farmers showed interest in the practices. Farmers indicated that the use of old ridges is easy to follow and labour saving.

During the planting period, farmers should plant maize and agroforestry tree seeds in rows, as recommended in specific areas. However, the rule of thumb is that maize should be planted with one seed per planting station spaced at 15 cm distances and the row should be made across the slope spaced at 75 cm of distance.

It should be emphasized that row spacing was previously at 90 cm distance each and this has been stopped because the current maize varieties do quite well at a shorter distance. The old ridge would die off as years go by while rain splash and human activity play a great role in levelling the maize field down.

2.2 Permanent planting basins

Climate change has affected smallholder agriculture with increased temperatures, changes in rainfall patterns, erratic rainfall and drought. Conservation agriculture proves to be adaptive to climate change when permanent planting basins are used as water conservation structures.

It has been witnessed that farmers across the country during conservation agriculture field days, organized by conservation

agriculture practitioners, that conservation agriculture plots with permanent planting basins retained enough soil water for crops to survive three to four day-dry spells.

This could be a potential investment in water shadow areas and dry areas.

Figure 1: Maize field under “old ridge” tillage or flat tillage in Nkhota Kota under MACC project of TLC in 2009



The permanent planting basins also act as focal points for the strategic application of nutrients such as chemical fertilizers, manure and biomass from agroforestry. Under conventional tillage, nutrients are not specifically directed to microenvironments accessible by the crop roots.

Year by year under conventional tillage, farmers change points for nutrient application because the ridges keep on changing. It then becomes cost-effective when all strategic nutrients are precisely applied within the proximate root radius, which is the farmers' area of concern.

All other land preparation operations will be carried out in the planting basins, and these include weeding, fertilizer application, tillage, manure application and others.

The permanent planting basins also have recommended row and basin spacing depending on different agro-ecological



zones. Since agro-ecological studies on the suitability of conservation agriculture and spacing trials on planting basins have not yet been conducted in Malawi, the rule of thumb is to maintain the recommended spacing used in conventional tillage.

However, suggestions have been developed on alternative planting basin spacing to be used by farmers depending on rainfall patterns and soil types.

Figure 2: Land preparation for permanent planting basins



It is very important for extension workers to get acquainted with the practical steps in constructing planting basins. It is noted that some NGO partners have disseminated confusing messages on planting basins.

These basins are meant to be permanent in the sense that the following years the farmer would not be required to construct new basins. It is encouraged that the farmers should prepare the basins during land preparation from June to October.

Digging planting basins only requires few tools and these are:

- a Malawian standard hoe or a chaka hoe;
- strings to mark out planting rows;
- measuring sticks or tape;
- pegs; and
- bottle tops.

If family labour may be used in addition and the field is relatively flat or a farrow, farmers should be encouraged to take time to re-align or dig basins correctly (as indicated in Table 1) so that in future years the same basins can be used.

If the farmer would like to use virgin land for conservation agriculture, it is encouraged to cut down all stumps, roots and trees. Ploughing is discouraged for tilling the virgin land to be used for conservation agriculture. Weeding is encouraged on previously cropped land prior to constructing basins.

For learning purposes, farmers are encouraged to start in a small area. Expansion of the area will take place as farmers get more skilled and convinced. Farmers can start with 0.5 ha (2 acres) of land. This would require a total of 8 888 basins using the current recommended plant population (see Table 1).

2.2.1 Marking out basins

To easily mark the basins' and the row's spacing, respectively, a straight line at the end of the field across and along the slope should be marked. Use Table 1 (above) for the spacing dimensions.

Calibrate the strings with clipped bottle tops to mark the row and the basin spacing. For example, following the current recommended plant population of 53 333 per hectare, basin strings and row strings will be clipped with bottle tops at 75 cm and 75 cm distances, respectively.

This will change with different configurations and plant population. Tie the calibrated strings to the peg at the end of the field and stretch the strings across the slope to the other peg to mark out the planting row where to dig the basins.



2.2.2 Constructing basins

Starting at the first bottle clip at one end of the string, stand to face across the slope (the way farmers were standing in making ridges) and construct each basin about 30 cm long, 15 cm wide and 20 cm deep.

The width of the basin is determined by the blade of the type of hoe used. In Zambia and Zimbabwe, farmers use chaka hoes which are of the width of 15 cm, but the Malawi standard hand hoe is about 20 cm wide. Farmers, therefore, construct planting basins that are wider than 15 cm. When the basins in the row have been completed to the end of the line, use the tape or measuring stick to mark the next row using the recommended spacing of 75 cm.

Repeat the process of constructing planting basins. The rows of basins can be

constructed in linear or staggered format. Some NGOs promote the use of staggered basins over linear basins in order to capture water and reduce runoff.

This should be encouraged in running slopes. Well-constructed basins will allow farmers to use correct amounts of seed, fertilizer and manure in the right place. This reduces wastage of resources, money and time.

3. Dealing with livestock problems

Livestock problems have been cited as one of the challenges of adoption of conservation agriculture by farmers in Malawi and other areas with agro-pastoral systems.

It has to be emphasized that livestock and conservation agriculture are still compatible, but a proper management system has to be put in place. Currently, in Malawi after crop harvest, livestock are let loose to forage on.

Table 1: Basin Spacing for different agro-ecological zones (with recommended seed density, basin density and plant population.)

Zones	Row spacing (cm)	Basin spacing (cm)	No. of maize seeds per basins	No. of planting basins per ha	Plant populations per ha
Areas with summer rainfall (Nov. to April) with relatively high temperatures and infrequent, heavy rainfalls, severe mid-season dry spells and sandy loams.	75	60	3	22 222	66 666
Areas with rainfall subject to frequent seasonal droughts and severe dry spells and very erratic rainfall and sandy, acidic soils.	75	75	3	17 777	53 333
Across agro-ecological zones (generic approach).	60	90	4	18 518	74 074

Source: ICRAF 2018



Figure 3: Maize planted in the permanent planting basins



Further reading

Conservation Farming Unit. 2007. Conservation Farming and Conservation Agriculture Handbook for hoe Farmers in Agro-Ecological Regions I & IIa - Flat Culture.

Garrity, D.P., Akinnifesi, F.K., Ajayi O.C., Sileshi G., Mowo J.G., Kalinganire A., Larwanou M. & Bayala J. 2010. Evergreen agriculture: a robust approach to sustainable food security in Africa. Food Security 2(3):197-214, ICRAF (2009) Evergreen Agriculture i.

Mloza-Banda, H.R., & Nanthambwe S. 2010. Conservation agriculture programmes and projects in Malawi: Impacts and lessons.

Sosola B.G., Sileshi G.W., Akinnifesi F. K., & Ajayi O.C. 2011. Conservation Agriculture Practices in Malawi: Opportunities and Challenges. Poster paper presented at Regional Conservation Agriculture Symposium, Johannesburg.

Zimbabwe Conservation Agriculture Task Force. 2009. Farming for the future: A guide to conservation agriculture in Zimbabwe.

Source: World Agroforestry Centre (ICRAF)



Livestock Production



Efficient livestock production that is raising domesticated animals to produce labor and commodities requires good management practices including appropriate feeding, animal health care, the selection and development of breeds.

Livestock includes a wide range of animals, e.g. cattle, goats, sheep, pigs, rabbits, chicken, ducks, guanacos and many others.

This category covers technologies and practices on the construction of animal housing, integrated crop-livestock farming systems, milk and meat production as well as on the production of other animal sub-products, e.g. honey or eggs. In addition, you can find practices and organizational techniques in the field of livestock production for social and economic community use of resources.

The livestock production category covers the Sustainable Development Goals of no poverty, zero hunger, good health and well-being, decent work and economic growth, responsible consumption and production, as well as life and land.

On the FAO-TECA platform, there are currently 215 technologies and practices within this category: 130 in English, 43 in Spanish, 40 in French and 2 in Portuguese.



8 Animal Husbandry in Organic Agriculture

Summary

Integrating animal husbandry into crop producing farms is one of the principles of organic farming. In temperate and arid zones, animal husbandry plays an important role in the recycling of nutrients, while it is less emphasised in the humid tropics. The caring, training, and nurturing of animals is considered an art in many farming communities.

Description

Integrating animals into a farm help creating a closed or semi-closed system where energy and nutrients are recycled. Animals can convert non-edible biomass (e.g. grass, straw, kitchen waste) into food while increasing soil fertility with their manure.

Figure 1: Animals integrated into the farm, showing the flow of fodder, dung and products



Many farm animals have a multi-functional role, for example, animals:

- produce dung, which is of great importance for soil fertility;
- yield products such as milk or eggs for sale

- or own consumption continuously;
- recycle by-products such as straw or kitchen waste;
- serve as draught animals for tillage or transport;
- produce meat, hides, feathers, horns, etc.;
- serve as an investment or a bank;
- help in pest control (e.g. dugs);
- help in weed management (e.g. grazing on barren fields);
- have cultural or religious significance (prestige, ceremonies, etc.); and
- produce young stock for breeding or sale.

Figure 2: Reasons to keep farm animals - A cow is not just a cow! Farm animals can have many functions for a farmer



The significance of each role will vary from animal to animal and from farm to farm. It will also depend on the individual objectives of the farmer.

1. Deciding on animal husbandry

There are several reasons for taking up animal husbandry as a part of your farming activities or even as the main one. There are also some critical aspects to be taken into consideration. To decide on whether and how to get involved in animal husbandry, you should ask yourself a number of questions:

1.1 Is my farm suitable?

Do I have sufficient space for shedding and grazing, fodder or by-products to feed, enough know-how on keeping, feeding, and treating specific kind of animals?



1.2 Will the animals benefit my farm?

Can I use the dung in a suitable way? Will I get products for my consumption or sales? Will the animals somehow affect my crops?

1.3 Can I get the necessary inputs?

Is sufficient labour available within or outside my farm? Is enough fodder and water of good quality available throughout the year? Will remedies and veterinary support be available, if needed? Can I get suitable breeds of animals?

1.4 Will I find a market for the products?

Does anyone want to buy my milk, eggs, meat etc.? Is the price worth the effort? Am I able to compete with other farmers?

1.5 What do animals need?

Organic farmers try to achieve healthy farm animals which can produce satisfyingly over a long period. To achieve this goal, various needs of farm animals have to be considered:

- fodder in adequate quality and quantity;
- for non-ruminants: diversity in fodder is usually required;
- sufficient access to clean drinking water;
- clean sheds of sufficient size and with adequate light and fresh air;
- sufficient freedom to move around and perform their natural behaviour;
- healthy conditions and veterinary follow-up, when needed;
- sufficient contact with other animals, but no stress due to overcrowding; and
- for herd animals: an appropriate age and sex distribution within the herd.

Organic animal husbandry means not only feeding organic food and avoiding synthetic food additives and synthetic medicines (e.g. antibiotics, growth hormones) but also focusing on satisfying the various needs

of the farm animals. Good health and welfare of the animals are among the main objectives.

Figure 3: What farm animals need - For example chickens have various needs which should be fulfilled simultaneous



© FAO/TECA

For example, sufferings from mutilation, permanent tethering or isolation of herd animals must be avoided as much as possible. For various reasons, landless animal husbandry (i.e. fodder purchased from outside the farm due to lacking grazing land) is not permitted in organic farming.

1.6 How many animals to keep?

To identify the appropriate number for a specific kind of animal on a farm, the following points should be considered:

- availability of fodder on the farm, especially in periods of scarcity (e.g. dry season);
- carrying capacity of pastures;
- size of existing or planned sheds;
- the maximum amount of manure the fields can bear; and
- availability of labour for looking after the animals.

In tropical countries, farm animals are frequently found to be underfed. When defining the number of farm animals, keep in mind that the economic benefit will be higher when fewer animals are kept, but fed well. Not only the amount but also the



quality of the available food must be taken into consideration.

2. Animal housing

The type of shed should be specific to the type of animals to be sheltered. Poultry, for instance, should be housed in sheds that do not get too hot. Contact of the animals with their faeces should be avoided as much as possible.

2.1 Planning sheds

Except for nomadic lifestyles, most farm animals are temporarily kept in sheds. The combination of animal husbandry and farm activities requires control of their movements to avoid damage to crops. For the welfare and health of the animals, sheds must be cool and aerated and protected from rain.

They should be constructed in a way ensuring:

- sufficient space to lie down, stand up, move and express natural behaviour (e.g. licking, scratching, etc.);
- sufficient light (as a rule, one should be able to read a newspaper in the shed);
- protection from sunlight, rain, and extreme temperatures;
- sufficient aeration, but no draught;
- appropriate beddings (see section below);
- elements to exercise natural behaviour (e.g. for poultry: perching rails, sand baths and secluded laying nests); and
- sheltered pits or heaps to collect and store manure.

For economic reasons, sheds can be built with simple, locally available materials. Many countries have a rich tradition of shed constructions and have developed the most efficient and appropriate shed systems for the conditions of the region. If techniques

of this heritage are combined with the above principles, a locally adapted and at the same time animal-friendly system may be obtained.

Figure 4: Traditional simple sheds in Senegal (cattle shed, goat shed, chicken shed)

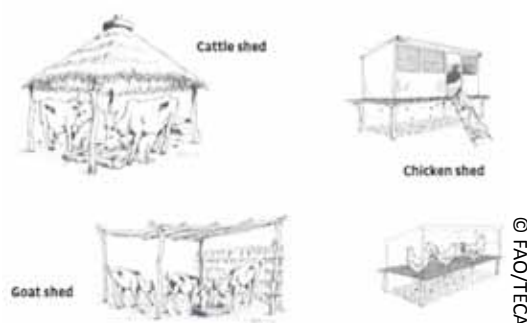

2.2 Beddings

Beddings are materials used in sheds for keeping the floor soft, dry, and clean, which is important for animal health. They absorb the excrements of the animals and need to be replaced from time to time. Beddings can be of straw, leaves, twigs, husks or other locally available material. They can be replaced daily or kept for several months while adding fresh material on top.

3. Animal Feeding

The availability of fodder is one of the limiting factors in animal husbandry. Unlike landless systems in conventional farming, organic husbandry should be mainly based on the fodder produced on the farm itself. As it is the case with humans, there is a direct link between the quantity and composition of the food and the health status of the animals.

3.1 Food Requirements of Animals

If farm animals are to be productive (milk, eggs, meat, etc.), it is important that they get suitable food in sufficient quantities. If the fodder production of one's farm is limited (which usually is the case), it



might be economically valid to keep fewer animals but supply them with sufficient food. The appropriate quantity and the mix of feed items will, of course, depend on the type of animal, but also on its main use (e.g. chicken for meat or egg production, cattle for milk, meat or draft, etc.). In milk production, for example, cows producing milk should be given fresh grass and possibly other feed items of sufficient protein content. On the same diet, draught animals would rapidly become exhausted.

A balanced diet will keep an animal healthy and productive. Whether or not a farm animal receives the appropriate amount and kind of fodder usually can be seen by the shine of its hair or feathers. For ruminants, a majority of the fodder should consist of roughage (grass, leaves, etc.). If concentrates or supplements are used (e.g. agricultural by-products and wastes), they should not contain growth promoters and other synthetic substances.

Instead of buying expensive concentrates, there are a variety of leguminous plants rich in protein which can be grown in the farm as cover crops, hedges or trees. If the mineral content in the available fodder is not sufficient to satisfy the animal's requirements, mineral salt bricks or similar feed supplements can be used as long as they do not contain synthetic additives.

3.1.1 Grazing versus shed feeding

In many regions of the tropics, favourable periods with abundant fodder alternate with less favourable periods when there is almost nothing to feed to the animals. However, keeping animals means providing fodder throughout the year. Fodder can be produced on the farm as grazing land or as grass or tree crops used for cutting.

While grazing requires less labour than shed feeding, more land is needed, and appropriate measures to keep the animals away from other crops must be undertaken.

Grazing may lead to lower productivity (milk, meat, etc.) but usually is the more favourable option concerning health and welfare of the animals.

Figure 5 (b): A variety of fodder grasses, both for shed feeding and pasturing



Figure 5 (b): Leaves and twigs of leguminous trees that are rich in protein and commonly available in the dry season



Shed keeping, however, has the advantage that the dung can be easily collected, stored, or composted and applied to the crops. Whether grazing or shed feeding is the more suitable option will mainly depend on the agro-climatic conditions, the cropping system, and the availability of land.

A combination of shed feeding and grazing in a fenced area may be an ideal combination of high productivity and animal-friendly husbandry. In extensive grasslands of semi-arid areas, however, grazing may be the only suitable option.



Figure 6: The pros and cons of grazing and shed feeding, and the combination of both systems as a promising option

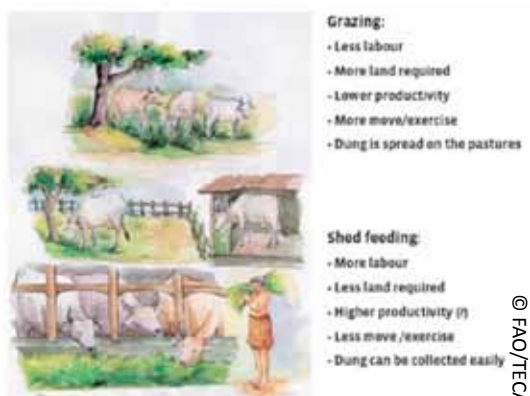

3.2 Integrating fodder cultivation in the farm

In most smallholder farms, fodder cultivation will compete for space with the cultivation of crops. Whether fodder cultivation (and thus animal husbandry) is economically more beneficial compared with crop production must be assessed case by case. However, there are some options for integrating fodder crops in farms without sacrificing much land. Below are some examples:

- grass or leguminous cover crops in tree plantations;
- hedges of suitable shrubs;
- shade or support trees;
- grass on bunds against soil erosion;
- grass fallows or green manures in the crop rotation; and
- crops with by-products such as paddy straw or pea leaves.

3.3 Management of pastures

The management of pastures is crucial for good herd management. It is also important to practice appropriate management throughout the year. There are many different types of grasses, and every climatic region has grasses, which are specifically adapted to the conditions. In

some cases, it may be worth considering to till the grazing site and sow grass varieties that are more appropriate to the animal's needs. Overgrazing is probably the most significant threat to grassland. Once the protective grass cover is destroyed, the top soil is prone to erosion.

Degraded pastures or land with little plant cover is difficult to re-cultivate. Therefore, it is important that the use and intensity of grazing on a particular piece of land are appropriate to its production capacity. Sufficient time must be given to pasture to recover after intensive grazing. Fencing off areas and rotation of the grazing animals on several pieces of land is the best option for managing the farm and the overall landscape. Creating grazing cells restores overgrazed pastures, reduces the incidence of intestinal parasites encountered while the animals graze, and increases land productivity. The intensity and timing of grazing, as well as the cutting of the grass, will influence the varieties of plants.

4. Animal health

Disease-causing germs and parasites are present almost everywhere. Like humans, animals have an immune system, which is usually able to cope with these germs. As with humans, the efficiency of the immune system will be disturbed if animals are not properly fed, cannot practice their natural behaviour, or are under social stress.

Health is a balance between disease pressure (i.e. the presence of germs and parasites) and the resistance (i.e. immune system and self-healing forces) of the animal. The farmer can influence both sides of this balance by reducing the number of germs by maintaining good hygiene and strengthening the animals' ability to cope with germs.



Figure 7: Cattle grazing on a pasture in Cuba



Organic animal husbandry puts its focus on improving the living conditions of animals and on strengthening their immune systems. Of course: if an animal gets sick, it must be treated. Nevertheless, the farmer should also think about why the immune system of the animal was not able to fight the disease or the parasite attack.

Also, the farmer should think of ways to improve the animals' living conditions and hygiene in order to strengthen it.

4.1 Prevention before curing

Similar as in crop health, organic animal husbandry puts the main emphasis on preventive measures in order to keep animals healthy, rather than on curative methods.

This starts from keeping robust rather than high performing but very susceptible breeds. Next, the conditions in which the animals are kept should be optimal, providing sufficient space, light and air, dry and clean bedding, frequent exercise, e.g. grazing, and proper hygiene.

The quality and quantity of fodder are of crucial importance for the health of the animal. Instead of feeding commercial concentrates, which make animals grow faster and produce more, a natural diet appropriate to the requirements of the

animal should be achieved. Where all these preventive measures are taken, animals will rarely fall sick. Veterinary treatment thus should play only a secondary role in organic farming.

If treatment is necessary, alternative medicine based on herbal and traditional remedies should be used. Only if these treatments fail or are not sufficient, synthetic medicines (e.g. antibiotics, parasiticides, anaesthetics, etc.) may be used; in these cases, the treated animals must be separated from non-treated organic stock and excluded for a period of time, e.g. at least 3 weeks, from organic certification.

Figure 8: Factors influencing animal health

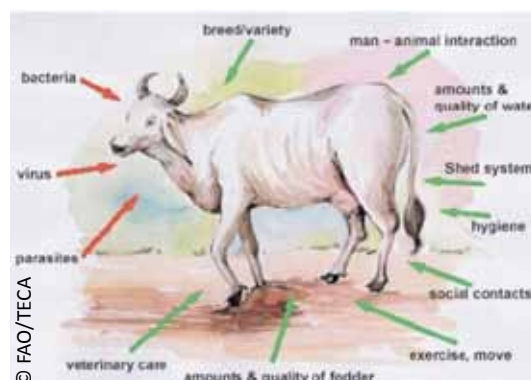

The principal reason for veterinary treatment in organic animal husbandry is exploring the causes of (or factors that favour) diseases in order to enhance the natural defence mechanisms of the animal (and to prevent its manifestations in the future).

Unlike in crop production, synthetic means are allowed to cure sick animals if an alternative treatment is not sufficient. Here, reducing the suffering of the animal is given priority over the renunciation of chemicals. However, the standards of organic agriculture clearly demand that priority



is given to management practices, which encourage the resistance of the animals and thus preventing the outbreak of a disease. Therefore, an outbreak of disease shall be considered as an indicator that the conditions under which the animal is kept are not ideal. The farmer should try to identify the cause (or causes) of the disease and prevent future outbreaks by changing management practices.

If conventional veterinary medication is applied, withholding periods must be adhered to before the animal products can be sold (as organic). This shall ensure that organic animal products are free from residues of antibiotics, etc. Synthetic growth promoters are not allowed in any case.

Figure 9: Prevention before curing - Only when all preventive measures fail animals should be treated, preferably with alternative remedies

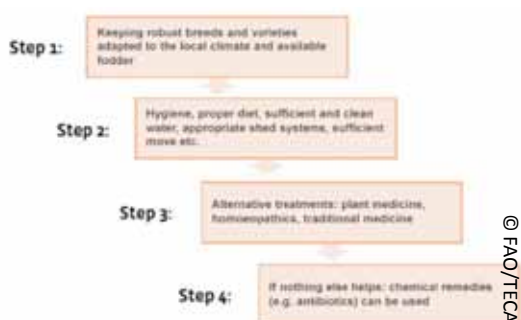

4.2 Controlling parasites with herbal remedies

Herbal medicines are widely used in many countries. Some traditional farming communities have a vast knowledge of local plants and their healing properties. Plants can definitely support the healing process, even if they do not eliminate the germ of the disease directly.

Still, farmers should not forget to identify the cause of the disease and also to re-think their management practices. For parasite problems, changing the living conditions

or the management of pastures will be more effective in the long run than any treatment.

4.3 Example: Using Sweet Flag against parasites

One example to use a herbal remedy against parasites is the sweet flag (*Acorus calamus*). This plant grows both in tropical as well as subtropical regions and is found on the banks of rivers and lakes and in swampy ditches or marshes. The powdered dried rhizomes (thick root parts) act as an effective insecticide against fowl lice, fleas and houseflies.

Figure 10: Using sweet flag (*Acorus calamus*) against parasites

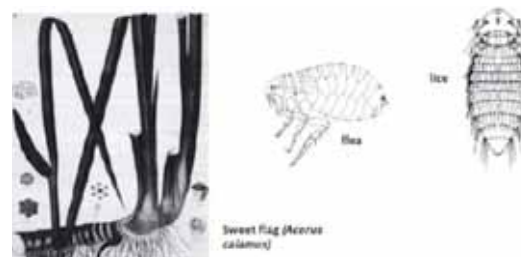

Source: "Ectoparasites in the Tropics", Matzigkeit, 1990

Treating fowls infested by lice: Use around 15 g of powdered rhizome for an adult bird. For dusting the bird with the powder, hold it by its feet upside down, so that the feathers open and the dust will work its way to the skin. The treatment is reported as being safe to the birds. The sweet flag powder is also reported to be effective against house flies when dusted on fresh cow dung infested by fly maggots. It further shall protect newborn calves of vermin infection if washed with a water infusion.

Attention! Herbal remedies against parasites can also have a toxic effect on farm animals! Therefore, it is important to know the appropriate dose and application method!



4.4 Principles and methods

As preventive measures for maintaining good animal health are of high relevance in organic farming, the selection of breeds suitable to local conditions and to organic feeding, is of crucial importance.

This requires that suitable breeds are available. Traditional breeds of farm animals may be a good starting point for organic animal breeding. Animals can be improved by the selection of individuals especially suitable for organic conditions. They can be crossbred with suitable new breeds, thus achieving an animal with the positive aspects of traditional breeds and the satisfying production capabilities of the new breeds.

For breeding, organic farming uses natural reproduction techniques. While artificial insemination is allowed, embryo transfer, genetic manipulation and hormonal synchronisation are not permitted according to the IFOAM standards.

5. Breeding Goals

Over the last decades, traditional ones have been replaced by high performing breeds in many regions. Similar to high yielding plant varieties, these new breeds usually depend on a rich diet (e.g. concentrates) and optimal living conditions.

As high performing breeds, in general, are more susceptible to diseases than traditional varieties, they need frequent veterinary interventions.

Thus, these new breeds might not be the right choice for small farmers, as the costs of food concentrate and veterinary treatments are too high compared to what can be earned by selling the products.

In addition, for organic farmers, the main animal product (e.g. milk) is not the only reason to keep animals. Breeding activities, therefore, should try to optimize the overall performance of the animal, taking into consideration the different goals of an organic farmer. For example, a poultry

Figure 11: Breeding goals

The «ideal» organic poultry breed

- Feeding on kitchen wastes and farm by-products
- Satisfying egg production
- Useful as meat
- Good health, good resistance against diseases



The «ideal» organic cattle breed

- Utilising roughage and farm by-products
- Satisfying milk production
- High fertility
- Good resistance against diseases
- Long life with continuous production



© FAO/TECA

Organic animal breeding should optimize the overall use of farm animals, with consideration given to the local conditions and available fodder: breeding goals for poultry and cattle breeding.



Table 1: Example Table for comparing the economic performance of two different breeds

Item	Breed A	Breed B
Investments		
Costs of a calf		
Costs of a cow		
Maintenance		
Fodder purchases per year		
Veterinary costs per year		
Milk production		
Litres per day		
Litres per year		
Productive years in life		
Litres per life		
Other uses		
Meat		
Draught		
Dung		

Source: IFOAM 2015

breed suitable for organic smallholder farms might not be the one with the highest egg production, but one in which meat production is good, and kitchen waste and whatever is found on the farmyard can be used as feed.

Suitable cattle breeds would produce sufficient milk and meat while feeding mainly on roughage and farm by-products (e.g. straw), be of high fertility and good resistance against diseases. If required, they can also be used for draught and transport.

5.1 Maximum performance or life production?

When comparing the production of different breeds of cows, usually, only the production per day or year is taken into consideration.

However, high performing breeds usually have a shorter lifespan than traditional ones with lower production capabilities.

The life milk production of a cow giving, for example, 8 litres per day, but over 10 years, therefore would be greater than the one of a high-breed cow yielding 16 litres per day, but dies after 4 years.

As the investments to get milk-producing cows are quite high, i.e. the rearing and feeding of a calf or the purchase of an adult cow, continuous production over a long lifespan should be of high interest to the farmer.

This should be reflected in the breeding goals, which so far mainly focused on the maximum short-term production.

6. Background

This is part of a training guide on Organic Agriculture. Further reading is available on the following topics:

- Introduction to Organic Agriculture;
- Considerations for Conversion to Organic Agriculture;



- Step by Step Conversion to Organic Agriculture;
- Mulching in Organic Agriculture;
- Water Management in Organic Agriculture;
- Crop Planning and Management in Organic Agriculture;
- Nutrient Management in Organic Agriculture;
- Pest and Disease Management in Organic Agriculture;
- Weed Management in Organic Agriculture
- Soil Cultivation and Tillage in Organic Agriculture;
- Plant Propagation in Organic Agriculture; and
- Animal Husbandry in Organic Agriculture.

All these techniques have been compiled by Ilka Gomez thanks to the collaboration of IFOAM, FiBL and Nadia Scialabba (Natural Resources Officer - FAO).

Further reading

IFOAM. 2003. Training Manual for Organic Agriculture in the Tropics. Edited by Frank Eyhorn, Marlene Heeb, Gilles Weidmann, pp190-209, <http://www.ifoam.bio>

Source: International Federation of Organic Agriculture Movements (IFOAM - Organics International)



Natural Resources Management



The natural resources management category addresses the responsible management of natural resources, e.g. water and soil. Water management technologies and practices in this category include different sources of water, e.g. groundwater, rainfall, ponds (lakes, lagoons, etc.), rivers, and marginal water and address the fields of water harvesting, drainage, crop irrigation, water distribution, water treatment, energy use, marginal water use, and monitoring.

Soil productivity management practices and technologies in this category, promote the maintenance and increase of soil fertility on cropland, pasture land, agroforest and forest land. They include both conventional methods (inorganic fertilization, soil tillage/ ploughing) and traditional practices. The latter include practices such as crop alternation, crop rotation, organic fertilization (manure, compost, mulching, etc.), green manuring (intercropping, cover crops, etc.), and zero or minimum tillage. Others address soil pH, soil assessment and erosion control.

For both soil and water, you can also find practices and organizational techniques for social and economic community use of resources.

The natural resources management category covers the Sustainable Development Goals of no poverty, zero hunger, good health and well-being as well as responsible consumption and production.

On the FAO-TECA platform, there are currently 295 technologies and practices within this category: 189 in English, 51 in Spanish, 47 in French and 8 in Portuguese.



9 Risk reduction while manipulating pesticides

Summary

“Pesticide” is a broad term covering a range of products that are used to kill pests, including insecticides, herbicides, fungicides and rodenticides. These pesticides are toxic and can be very harmful to your health and the environment (especially for bees). But overuse of pesticides is not just dangerous for your health and the environment; it also wastes money and encourages pest resistance.

Here are some explanations and advice on how to safely use pesticides and how to protect you from the harmful effects of pesticides when applying them on the fields.

If you decide to use pesticides, get advice about the least hazardous ones to use and how to protect yourself from their effect.

Description

Pesticides, when entering in contact with you and/or the environment are harmful and can lead to negative effects on human and environmental health and development.

In a short time, contact with pesticides can cause:

- poisoning;
- skin or eyes irritation/burns;
- allergic reactions; and
- difficulties to breath, etc.

And in the case of long-term exposure, continuous contact with a pesticide can end in the development of:

- cancers;
- nervous or neurological disorders (e.g. paralysis, tremors, brain damages, etc.);
- diseases of blood, liver, kidneys or lungs (difficulties to breath, asthma, etc.); and
- infertility, reproductive disorders, fetal malformation, etc.

That is why pesticides always should be used with care!

1. Ways pesticides enter your body

1.1 Through your skin - this is common and can happen through clothes.

Figure 1: A man pouring pesticides in a plastic container while the pesticide hits his arm



1.2 Eating, smoking or drinking in contaminated areas.

Figure 2: Two men smoking and eating in an area contaminated by pesticide



Note: you can be exposed to pesticides by eating food that has not yet passed the recommended amount of days between the application of pesticides on it and its consumption.



1.3 Breathing - while you are using pesticides, or if you pass near contaminated areas.

Figure 3: A woman applying pesticides without facial protection



2. Exposure to pesticides

2.1 Exposure through spilling, mixing or applying pesticides.

Figure 4: A man pouring pesticides in a plastic container using proper safety clothing and protection and another man after spilling pesticides on the floor in a storage room



If you are exposed to pesticides and feel unwell: See a doctor, tell him or her you work with pesticides. Show the doctor the pesticide label.

Figure 5: A woman seeing a doctor after contact with pesticides



3. Precautions to take when buying pesticides

3.1 Always follow label instructions on use, safety, dose and first aid. Do not buy pesticides without labels or with labels in a language you do not understand.

Figure 6: A man carefully reading the safety instruction of a pesticide



3.2 Only buy pesticides in the original undamaged packaging.

Figure 7: A man pouring pesticides in a smaller container to sell it





4. Protecting your health when using pesticides

4.1 Use proper protective equipment that is in good condition and mix pesticides in a well-ventilated area while wearing protective equipment.

Figure 8: A man wearing adequate security clothing to handle pesticides and a woman pouring pesticides correctly using safety clothing and a funnel



4.2 Do not spray in windy or foggy conditions or against the wind.

Figure 9: A man incorrectly applying pesticides in volatile weather conditions including wind and rain



4.3 Do not blow into blocked spray nozzles.

Figure 10: A man incorrectly blowing into a blocked spray nozzle



4.4 After use, thoroughly wash (at least) your face and hands with soap before eating, smoking or going to the toilet.

Figure 11: A woman properly washing and cleaning all body parts that may have been in contact with the pesticide



4.5 Do not use leaking or defective equipment.

Figure 12: A man applying pesticides using dysfunctional tools





4.6 Wash contaminated skin and clothing with plenty of water and soap.

Figure 13: A man intensively washing and cleaning body parts and clothing that has been in contact with pesticides



4.7 Take care to avoid spills or accidents, especially during the transport of pesticides.

Figure 14: Carelessly stored pesticides before transport



4.8 Never leave pesticides and spray equipment unattended.

Figure 15: Pesticides left unattended and without supervision



4.9 Contaminated clothing should be washed and stored separately from ordinary clothes.

Figure 16: A woman carelessly storing safety clothing in her wardrobe



4.10 Place warning signs to alert people to stay out of recently treated crops.

Figure 17: A woman explaining the meaning of a safety instructions sign to a young boy



4.11 Keep children and expectant or nursing mothers away from pesticides (They are more easily affected by pesticides than men).

Figure 18: A woman staying away from a pesticide-infected field





4.12 Store pesticides securely; well away from foodstuffs and out of the reach of children and animals.

Figure 19: Safely stored pesticides



4.13 Empty pesticide containers are not safe, even after washing. Never use for foodstuffs or leave within reach of children. Always triple rinse and puncture before disposal so that they cannot be re-used.

Figure 20: A woman falsely using a pesticide container for fruit juice



5. Protection of consumers is key

5.1 Never use products on food crops that are not registered for that purpose.

Figure 21: A man falsely applying pesticides to a not registered food crop



5.2 Always observe the correct harvest interval (Respect the recommended amount of time between the date of treatment and the date of harvest/commercialization).

Figure 22: A woman calculating the correct application intervals for pesticides



Pesticides should always be used with precaution, and with respect to recommendations mentioned above and specific recommendations mentioned by the manufacturer in the pesticides' package.

Before purchasing and applying pesticides, please make inquiries from an agricultural adviser about alternative solutions, which are less harmful to you, your family, the consumers and the environment.

For instance, give priority to eco-friendly and sustainable practices such as crop rotation, biological control of pests, early detection of diseases, etc. It is important to only use pesticides when necessary, not as prevention!

The European Union (EU) and the Food and Agriculture Organization (FAO) of the United Nations have invested EUR 7 million to assist countries in Central Asia and Eastern Europe to foster an environment of cooperation and capacity development to:

1. Eliminate the risks from obsolete and Persistent Organic Pollutants (POPs) pesticides.
2. Develop more sustainable agriculture in the future.



The project aims at strengthening the capacity of the civil society to contribute to reducing the risks and impacts from pesticide use onto public health and onto the environment.

One of the main focuses is the improvement in awareness of the risks of pesticide exposure amongst vulnerable groups, including women, children and seasonal workers in agriculture.

Supported by the Secretariat of the Rotterdam Convention and the Pesticide Action Network (PAN) the UK, this project delivers training and technical support to identify particularly hazardous practices and to promote higher safety standards and so reduce risk.

This leaflet has been produced with the assistance of the European Union in the framework of the project “Improving capacities to eliminate and prevent recurrence of obsolete pesticides as a model for tackling unused hazardous chemicals in the former Soviet Union”.

The contents of this leaflet are the sole responsibility of Pesticide Action Network (PAN) the UK and can in no way be taken to reflect the views neither of the European Union or the Food and Agriculture Organization of the United Nations (FAO).

Source: Plant Production and Protection Division (AGP) in FAO



Nutrition studies the interaction between nutritious foods and the maintenance, growth, reproduction, health and disease of organisms.

Technologies and practices under the category nutrition for a better life aim at creating sustainable improvements in nutrition to prevent malnutrition and diet-related diseases. You will also find technologies and practices on improved methods for preservation and processing of fruits, vegetables, fish and other animal products improving nutritious food intake.

The nutrition for better life category covers the Sustainable Development Goals of no poverty, zero hunger, good health and well-being as well as responsible consumption and production.

On the FAO-TECA platform, there are currently 57 technologies and practices within this category: 50 in English, 6 in French and 1 in Portuguese.



10 How to harvest honey, pollen and propolis from stingless bees

Summary

Beyond honey, hive products like pollen and propolis can be gathered easily from stingless bees, representing a possible additional source of income for farmers. This technology explains simple procedures for gathering honey, pollen and propolis from stingless bees.

Description

One easy way to harvest pollen and honey is to extract them from coconut shell hives. The honey is ripe and ready to be harvested when the honeypots are sealed. If this is the case, then the content of the coconut shell chamber can be checked with a clean bamboo stick (see Figure 1). Lift the chamber containing the honey and pollen stores and replace the removed shell with the new ones (see Figure 2).

Harvesting honey, pollen and propolis are explained in more details in the following sections.

1. Harvesting honey

1.1 Coconut Shell

First, scrape the honey and pollen off the shell. Then, separate the honey from the pollen pots. Honey can be dripped or pressed from the pots. Second, pass the honey through a fine mesh sieve into a settling tank, and leave the honey to settle for at least one week. Keep it bottled and sealed because honey may be contaminated with airborne yeast and

bacterial spores during harvest. Due to high moisture, yeast spores germinate and thus ferment the honey. Third, the honey should be pasteurized especially when the moisture content is higher than 23 percent.

Figure 1: Checking pot content with a bamboo probe



Pasteurization will kill the yeast that causes fermentation. To pasteurize, place the honey bottles in a saucepan filled with water and heat it up to 62 °C (approximately 145 degrees Fahrenheit) for about 30 minutes. The moisture content of honey is measured using a refractometer.

1.2 Wooden Hives

In wooden hives, supers are managed to contain honey or pollen only. When full, honey supers are removed. The honeypots are cut and removed, and the supers returned to the colony. The pots are sliced into smaller sized cubes and placed in a press or allowed to drip. Similarly, the honey is strained and allowed to settle before bottling. Pasteurize the honey using the procedure described above.

2. Harvesting pollen

Pollen is manually separated from its pots with clean bamboo or stainless steel spoons. Then, the clean pollen is spread out on screened trays and air dried under shades protected from sunlight. If not, exposure to direct sunlight will darken the pollen. Under



ambient temperatures between 30 to 33 °C, the air-drying will take around three days. Also, the moisture content of pollen must be controlled. The standard value for pollen moisture should not exceed 6 percent as dried pollen crumbles when pressed.

Finally, the cerumen and pots are cut into small chips and spread evenly on screened trays as well as air dried.

Dried pollen and cerumen are placed in food-grade plastic bags and vacuum sealed (if the equipment is available).

Figure 2: Opening nest and replacing store chamber



Figure 3: Pressing honeypots



Figure 4: Pollen and honeypots inside a cocoa shell





Figure 5: Removing pollen from pots.



Figure 6: Clean pollen pellets



3. Harvesting propolis

First, propolis is gathered by cutting 1 cm x 1 cm propolis sheaths around the nest, with a distance of around 6 cm in between to minimize the damage in the nest. The procedure may be repeated after two weeks when the open spaces have been fully mended. Second, the gathered propolis should be cleaned to remove debris such as mud, dried leaves and sawdust that the bees mix them with.

While cleaning the operator, it is recommended to wear rubber or vinyl gloves. Third, air-dry the propolis for around three days. Dry propolis is less pliable and relatively hard compared to freshly harvested ones. Forth, pack in clean plastic bags. The propolis can now be used as raw

material for making cosmetics, ointments and component of drugs.

Figure 7: Removing propolis/cerumen from the inside of a coconut shell



Dried pollen and wax should be stored in a clean, cool and dry room to prevent the growth of moulds. You can store the honey in a glass or food grade container. Store the



honey away from the sunlight. Make sure that the lids are tightly sealed.

Figure 8: Propolis/cerumen flakes ready for drying



Further reading

Cervancia, C.R. Fajardo, A.C. Manila-Fajardo, A.C and Lucero, R.M. 2012. Management of Philippine Bees: Stingless Bees and Honey Bees. With Bibliography of Philippine Bees. University of the Philippines Los Baños. ISBN 978-971-547-272-2. Pp. 71.

Fajardo, A.C. JR., & Cervancia, C.R. 2003. Simple ways to manage stingless bees. Bees for Development. 67:3-5.

Source: University of the Philippines, Los Baños



Post Harvest and Marketing



Post-harvest and marketing strategies aim at enhancing the agricultural and economic activities during and between the harvest and the commercialization of produce.

This category is concerned with practices and technologies including activities of preservation and storing, processing, transporting and marketing for a variety of agricultural products, such as grains and cereals, fruit and vegetables, roots and tubers, dairy and livestock products among others.

The post-harvest and marketing category covers the Sustainable Development Goals of no poverty, zero hunger, decent work and economic growth as well as responsible consumption and production.

On the FAO-TECA platform, there are currently 142 technologies and practices within this category: 100 in English, 5 in Spanish, 16 in French and 21 in Portuguese.



11 Increasing the yield of mango with selective harvest

Summary

Due to inaccurate methods of harvesting, farmers tend to deteriorate the quality of mangoes and obtain reduced yields of the fruit resulting in a loss of income of the farmers. Through selective harvesting techniques, mangoes are harvested in three stages from the trees based on their maturity level. Also, proper picking poles are used to harvest the mangoes in order to avoid dropping them on the ground causing subsequent damage. This technique explains how to harvest mangoes properly and how the mango harvest can be planned in order to reduce post-harvest losses.

Description

Harvesting of mangoes at an incorrect point in time results in a loss of yield of mangoes: the mangoes are either too ripe or not ripe enough. This loss is further increased due to the damages caused to the mango while plucking. Farmers usually pluck all the mangoes when most of the fruits are ready for harvest. However, the mango flowers grow at different times, and hence the fruits also do not mature at the same time. Hence, at the harvest, nearly 50 percent of the fruits are at the right maturity level while the remaining 50 percent are either over-ripened or under-ripened. As a consequence, farmers lose nearly half the income due to the rejection of the fruits which are not at the correct maturity level. The immature fruits will never ripen since they lack the

nutrients from the mother plant while the over-ripened mangoes will spoil very quickly. In addition, leaving over-ripened mangoes on the trees is dangerous: they attract birds, fruit flies and diseases onto the farm.

Using selective harvest techniques, the mango harvest can be done in different stages in an organized way promising increased harvest yields. The fruits can be classified roughly into three different maturity levels. The farmer can mark the branches with different colour tags where flowers appear at the same time for convenience during harvest.

At the beginning of the flowering season, the farmer can attach red flags to branches with the first flowers. Branches with the next batch of flowers can be marked yellow and the last batch with green flags. The dates of the flowering need to be recorded by the farmer.

Figure 1: Farmer recording the dates of the flowering of buds and marks the branches with different colour tags



The mangoes can be harvested in three different sessions by judging the maturity of the fruits, i.e. selectively harvesting only matured fruits in a session.

- For the first session, the farmers can harvest the fruits from the branches



marked red depending upon the type and date of planting.

- For the second session, the fruits on the branches marked yellow can be harvested after 7 to 10 days depending upon the maturity level.
- For the last session of the harvest, the branches marked with green flags can be harvested 7 to 10 days after the second harvest.

The fruits on the branches with similar colour tags will mature roughly at the same time. Still, maturity tests should be performed for a good harvest.

1. Assessing the right harvesting moment by carrying out the maturity test

The maturity level of the mangoes can be assessed by two methods: (1) the preliminary and (2) the destructive analysis.

The preliminary check can be performed using visual aid while the destructive check requires cutting open the fruit.

After preliminary non-destructive maturity tests, a few samples from the similar batch are checked using the destructive assessment of matured fruits.

1.1 Preliminary maturity assessment

There are three ways in which the maturity of the mango fruit can be detected.

1.1.1 The neck is checked, and the panicle drops inside for a matured fruit as shown in Figure 2.

1.1.2 On the fruit skin, there are tiny spots present, known as lenticels. These lenticels are brown in colour for a matured fruit. For un-ripened fruits, these lenticels are either white or yellow in colour (compare Figure 3).

Figure 2: The panicle drop in matured mangoes

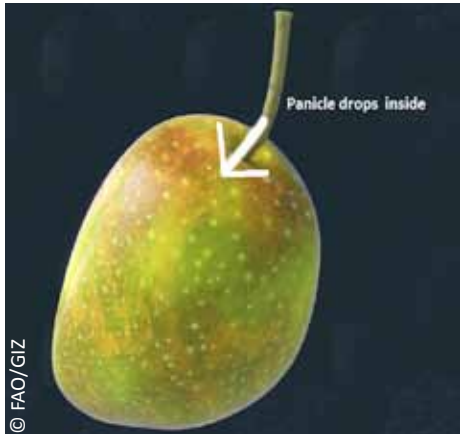

Figure 3: Brown lenticels of the ripe mango



1.1.3 After reaching maturity, the stalk (hanging point of the fruit) begins to dry since it no longer requires nutrients from the mother plant (see Figure 4).

Figure 4: A dried up stalk of the ripe mango





1.2 Destructive maturity assessment

The destructive maturity assessment consists of two tests:

1.2.1 Check the Brix level (i.e. sugar content): To check the brix level of the mango, a refractometer is required. The fruit needs to be cut into three parts as shown in Figure 5.

The juice of the part cut in Figure 5 (b) is poured on the refractometer and directed towards the sun. The refractometer scale gives the brix level of the fruit. Higher values indicate more sweetness and lower values less. Usually, for a brix level of greater than 9 degrees, the fruit is considered mature.

1.2.2 Check the internal colour: A colour chart ranging from white to deep yellow

is often used to determine the different growth stage of the fruit. The remaining part of the mango (cut to check the brix level) is matched against the chart to determine the exact state of the maturity of the mango. The colour of the matured fruit varies depending upon the variety of the mango.

Both the brix level and the colour chart values help to determine the exact maturity level of your fruits.

The specific values of brix level and colour chart indicators differ depending upon the requirement of the buyers (for local consumption, import or for the manufacture of fruit juices or dry fruits). Hence, the requirements of the buyer need to be checked before the harvesting

Figure 5: Mango cut in three equal parts (a) through the seed, and (b) middle of the edge and the seed.

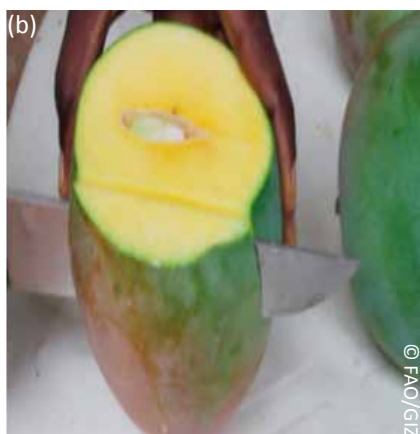
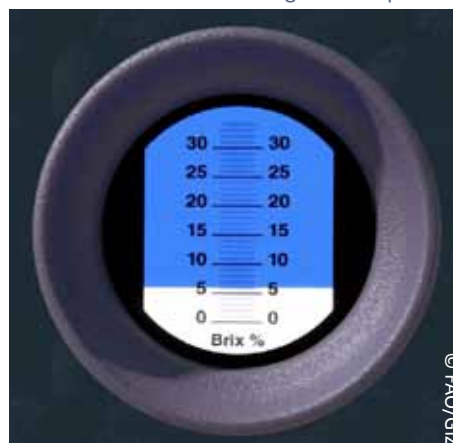

Figure 6: The mango juice being tested on a refractometer for its sugar content



Figure 7: Brix scale inside the refractometer. Meter indicates a brix level of 6: the mango is not ripe





season arrives and harvest should be planned accordingly.

Figure 8: A typical colour chart to check the maturity

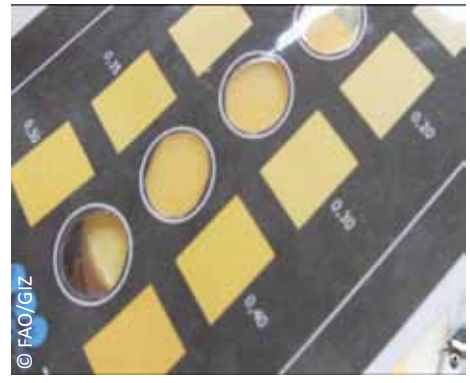

2. Reduce damage by using the right picking pole

Once the fruits to be picked are selected, they should be plucked without causing any harm to the fruit. Many farmers currently use a hook on the end of a stick to hook the mango and pull it so that the mangoes are dropped from the tree into the ground. The fruits dropped from above 2 m height suffer internal cracks often unnoticed by the farmers from the outside. Upon coming in contact with the ground, the chances of fungal infections in the fruit also increase. Hence, proper picking poles which are able to hold the mangoes should be used.

The mangoes should then be gently transferred into a plastic crate. The mangoes stored in such crates have proper ventilation, and thus there are fewer chances of damage. The picking poles should be disinfected with spirit or alcohol before use to avoid the spreading of diseases. These practices improve the hygienic standard of the harvest. The selective harvesting technique is labour intensive and requires an initial investment on correct harvesting tools, but this limitation can be easily defeated by the added benefits of the higher yields. This

method of harvesting allows the farmer to harvest mangoes at the right time of maturity.

Figure 9: A man using a picking pole for mango harvest



This increases the yield of mangoes to nearly twice, which is a major economic benefit to the farmers in terms of increased income. Also, the increased quality of the fruit through improved picking practices can receive higher prices for the fruits sold to the suppliers.

Figure 10: Women in Ghana carrying mangoes in a plastic crate





























This technique also reduces the chance of spreading diseases through over-ripened mangoes. Farmers growing mangoes in every part of the world can benefit from this technique to harvest the mango.

Source: GIZ - Market-Oriented Agriculture Program (MOAP)

List of related technologies

Readers of this catalogue could also be interested in related technologies and practices available in the TECA Knowledge Base or in specific moderated discussions hosted by TECA. The technologies and practices listed below can be consulted online (<http://www.fao.org/teca>).

	Language	Title of the technology or practice in the languages available	Technology or practice by partner	Sustainable Development Goals
Technology or practice				
Pest and Disease Management in Organic Agriculture	French	La gestion des ravageurs et des maladies en agriculture biologique	IFOAM - Organics International, The Research Institute of Organic Agriculture (FiBL)	     
	Portugues			
	Spanish	Manejo de plagas y enfermedades en la agricultura orgánica		
	Russian	Защита растений от вредителей и болезней в органическом сельском хозяйстве		
Good Practices for the Establishment of a New Cashew Farm	French	Comment Créer Un Nouveau Verger d'Anacardiérs	GIZ - African Cashew Initiative	    
	Portugues	Como estabelecer um novo pomar de caju		
	Spanish			
	Russian			
Guide to Harvesting and Post-harvest Handling of Cashew Nuts	French	Bonne Pratique de Récolte et Post-récolte des noix de cajou	GIZ - African Cashew Initiative	    
	Portugues	Guia para colheita e manuseio pós-colheita da castanha de caju		
	Spanish			
	Russian			
Livestock Refuge Mounds to Strengthen Resilience Against Natural Hazards in Bolivia	French		FAO Bolivia	     
	Portugues			
	Spanish	Lomas de resguardo ganadero con parcelas de cultivos aledaños para épocas de inundación y de sequía, en Bení, Bolivia		
	Russian			
Main Diseases of Honey Bees	French	Les principales maladies des abeilles	Apimondia, IZSLT - Istituto Zooprofilattico Sperimentale del Lazio e della Toscana "Mariano Aleandri"	    
	Portugues			
	Spanish	Principales enfermedades de las abejas melíferas		
	Russian			

The FAO-TECA Platform

TECA is an FAO online platform for the exchange and sharing of agricultural technologies and practices for smallholder farmers and producers. The platform facilitates the transformation process in rural areas by making relevant and innovative technologies available to farmers in the field. In doing so, TECA further enhances the access to knowledge of smallholder producers in rural areas increasing their capacity to innovate and contribute to achieving the Sustainable Development Goals (SDGs).

The FAO-TECA Knowledge Base currently contains over 900 technologies and practices from around the world. They include effective techniques, tools, practices and skills that have been validated by technical experts and adopted by smallholder farmers. Each technology is developed to be easily replicated and presents detailed descriptions, videos and illustrations. FAO-TECA technologies and practices use a non-academic language and are designed to match the needs of smallholder farmers.

About this catalogue

This catalogue promotes a set of successful innovations for farmers on the occasion of the FAO International Symposium on Agricultural Innovation for Family Farmers: Unlocking the potential of agricultural innovation to achieve the Sustainable Development Goals, which will be celebrated in FAO Headquarters on 21-23 November 2018.

The technologies presented are concrete actions that have solved specific development challenges and promote sustainable and inclusive rural transformations. The technologies and practices are designed following the FAO-TECA platform standards and have been tested and refined in the field. Each practice supports smallholder farmers and those providing advisory services to agricultural producers, to identify specific needs, select the correct practices and to implement technologies adequately.

Developed with the help of FAO in cooperation with the FAO Departments of Agriculture and Consumer Protection, the Department of Fisheries and Aquaculture and other key partners, the GIZ, ICRAF, IFOAM and Swisscontact, this catalogue aims at illustrating how sharing knowledge may unlock innovation throughout the farming process.



Objective

Helping smallholder farmers and organizations identify opportunities for replicating and documenting successful innovations, technologies and practices to improve livelihoods adapted to their specific context.

Illustrating how FAO-TECA technologies fill a gap in assisting partners in reaching out to smallholder farmers, how FAO-TECA technologies and practices are described and presented and how producers in the field are provided with potential innovations to the challenges they face on a daily bases.

e-mail: TECA@fao.org
website: www.fao.org/teca
FOOD AND AGRICULTURE ORGANIZATION
OF THE UNITED NATIONS
Viale delle Terme di Caracalla
Rome, Italy

